



A Safe Fleet Brand



# PRESSURE GOVERNOR and ENGINE MONITORING MODEL: PBA400



**FIRE RESEARCH CORPORATION**

[www.fireresearch.com](http://www.fireresearch.com)

26 Southern Blvd., Nesconset, NY 11767

TEL 631.724.8888 FAX 631.360.9727 TOLL FREE 1.800.645.0074

**CONTENTS****Table of Contents**

CONTENTS.....	2
INTRODUCTION .....	4
Overview.....	4
Features.....	4
Specifications.....	5
GENERAL DESCRIPTION.....	6
Controls and Indicators.....	8
INSTALLATION .....	10
Install Control Module.....	10
Install Pressure Sensor.....	12
Install Engine Sensors.....	13
Install Buzzer.....	13
Install High Idle Kit.....	13
Install Remote Governor Option.....	13
OPERATION .....	14
Controls.....	14
Error Codes and Fault Warnings.....	15
Pressure Mode Operation.....	16
RPM Mode Operation.....	18
Switching Between Operating Modes .....	19
Pump Discharge Pressure is High at Engine Idle .....	19
RPM Limit with Discharge Pressure Less than 100 PSI.....	19
Remote Governor Option.....	19
Detailed Information.....	20
High-Idle.....	20
Preset Settings (Pressure or RPM).....	21
PROGRAMMING .....	22
Access Password Protected Programs .....	24
CALIBRATION.....	26
Pump Pressure Sensor (Code C1 and C2) .....	27
Engine RPM (Code C3).....	27
WIRING.....	28
Connectors and Cables.....	28
Secondary Controller, Cables and Connections.....	29
Pressure Sensor.....	30
Common OEM Diagnostic Connector.....	31
Cummins Harness Connections.....	32
Detroit Diesel Harness Connections.....	33
Navistar Harness Connections.....	34
Navistar / International Chassis Harness Connections .....	35
Caterpillar Harness Connections .....	36

Ford Harness Connections .....	37
Mack Harness Connections .....	40
Scania Harness Connections—Type A .....	41
Scania BCI Harness Connections—Type D .....	42
Mercedes Harness Connections .....	43
John Deere Harness Connections .....	44
MAN Harness Connections .....	45
IVECO Harness Connections .....	46
High-Idle Wiring.....	47
FLYBACK DIODE INFORMATION .....	48

## List of Tables

Table 1. Pressure Sensor Output Voltage .....	5
Table 2. Error Codes .....	15
Table 3. Fault Warning Codes.....	15
Table 4. Operator Password Protected Program Functions .....	25
Table 5. Calibration Codes Quick Reference Chart.....	26

## List of Figures

Figure 1. Controls and Indicators.....	9
Figure 2. Control Module Mounting Dimensions.....	11
Figure 3. Pressure Sensor Dimensions.....	12
Figure 4. PBA Connectors .....	28
Figure 5. PBA Connector Wiring.....	29
Figure 6. Pressure Sensor Wiring.....	30
Figure 7. Common OEM 9-Pin Diagnostic Connector.....	31
Figure 8. Cummins PBA401 Wiring.....	32
Figure 9. Detroit Diesel PBA402 Wiring.....	33
Figure 10. Navistar PBA404 Wiring.....	34
Figure 11. Navistar/International Chassis PBA404 Wiring.....	35
Figure 12. Caterpillar PBA405 Wiring .....	36
Figure 13. Ford PBA406 J1939 Translator Module Wiring .....	38
Figure 14. Ford PBA406 PCM Wiring .....	39
Figure 15. Mack PBA407 Wiring .....	40
Figure 16. Scania PBA408 Wiring—Type A .....	41
Figure 17. Scania BCI PBA408 Wiring—Type D .....	42
Figure 18. Mercedes PBA410 Wiring.....	43
Figure 19. John Deere PBA416 Wiring.....	44
Figure 20. MAN PBA424 Wiring.....	45
Figure 21. IVECO PBA426 Wiring.....	46
Figure 22. High-Idle Wiring .....	47
Figure 23. Flyback Diode .....	48

---

# INTRODUCTION

## Overview

The Fire Research pressure governor uses state-of-the-art-programmable microprocessor technology and operates in one of two modes, pressure or RPM. It maintains a steady pump discharge pressure within system capabilities by controlling the engine speed or holds a selected engine RPM.

The PBA400 has two pressure sensors that monitor both the pump intake and discharge pressure. The dual sensor configuration provides improved defense against pump cavitations.

In pressure mode the governor maintains a constant pump discharge pressure. The discharge pressure is monitored and compared to the selected pressure setting, the engine RPM is varied to keep the discharge pressure at the selected setting.

In RPM mode the governor maintains a constant engine RPM. The pump discharge pressure is monitored, it can vary but is limited to an increase of 30 PSI. If the discharge pressure increases 30 PSI, the pressure governor automatically lowers the engine RPM to reduce the discharge pressure.

All controls and indicators are located on the front of the control module.

## Features

- J1939 CAN Bus for Engine Information and Control

- Power Up in Pressure Mode

- Automatic Regulation of Pump Discharge Pressure

- Manual Control of Pressure or Engine RPM Settings

- Programmable Presets

- Diagnostic Capabilities

- No Pressure or RPM Variation When Changing Modes

- Limits Increase of Pressure When in RPM Mode

- Recognition of No Water Condition With Automatic Response

- Interlock Signal Recognition with Throttle Ready LED

- Return to Engine Idle With the Push of a Button

- Display Brightness Automatically Adjusts for Day or Night Operations

- High Idle

- Audible Alarm Buzzer (Optional)

- KPa / Bar (Optional)

- Remote Governor Option

## Specifications

The governor is available in various models. Each model is programmed to interface with specific engines. All models provide the same functions, controls, and digital readouts for the management of pump discharge pressure.

### Display Module

Supply Power:	12/24 VDC
Supply Current:	0.5 Amps
Dimensions:	4 5/8" Wide by 6 3/4" High

### LED Bar Graphs

Oil Pressure:	10 - 100 PSI
Temperature (Engine Coolant):	150 - 240 °F
Transmission Temperature:	140 - 300 °F
Battery Voltage:	11.5 to 15.5 VDC (12 V) 23.0 - 30 VDC (24 V)

### Engine Sensors

Engine Oil Pressure:	0 - 100 PSI, 1/8" NPTF
Engine Coolant Temperature:	100 - 250 °F, 1/2" - 14 NPT
Transmission Temperature:	140 - 320 °F, 1/8" NPTF

### Pressure Sensor

	Discharge	Intake
Model Number:	XE-FP4000PT3	XE-IO3100PT3
Pressure Range:	0 - 600 PSI	-30 in/Hg - 600 PSI
Proof Pressure:	1200 PSI	1200 PSI
Excitation Voltage:	5 VDC	5 VDC
Output Voltage:	0.5 - 4.75 VDC (See Table 1)	

**Table 1. Pressure Sensor Output Voltage**

	0psi	100psi	150psi	200psi	250psi	300psi	600psi
Discharge Sensor XE-FP4000PT3	0.5vdc	1.21vdc	1.56vdc	1.92vdc	2.27vdc	2.625vdc	4.75vdc
Intake Sensor XE-IO3100PT3	0.604vdc	1.295vdc	1.640vdc	1.985vdc	2.331vdc	2.667vdc	4.75vdc

---

## GENERAL DESCRIPTION

The pressure governor is compatible with the following engines:

PBA401	Cummins IS Series
PBA402	Detroit Diesel
PBA404	Navistar
PBA405	Caterpillar
PBA406	Ford
PBA407	Mack
PBA408	Scania
PBA410	Mercedes
PBA416	John Deere
PBA424	MAN
PBA426	IVECO

### Components

The information available on the J1939 databus varies depending on the particular engine type. Not all wires are used for all engines. Refer to the engine specific wiring diagram for interface connections. The sensors (if any) that need to be installed also vary depending on the engine.

The governor consist of the following components:

Control Module

Discharge Pressure Sensor

Intake Pressure Sensor

Engine Oil Pressure Sensor (As Necessary)

Engine Coolant Temperature Sensor (As Necessary)

Transmission Temperature Sensor (As Necessary)

Audible Alarm Buzzer (Optional)

Cables

---

## **Control Module**

The control module is waterproof and uses 4 5/8 by 6 3/4 inches of panel space. All controls and indicators are located on the front of the control module. (Refer to Controls and Indicators.)

### **Discharge Pressure Sensor**

The pressure sensor is mounted on the pump discharge manifold. It provides an input signal to the control module that is proportional to the pressure.

### **Intake Pressure Sensor**

The pressure sensor is mounted on the pump intake manifold. It provides an input signal to the control module that is proportional to the intake pressure.

### **Engine Oil Pressure Sensor**

The oil pressure sensor is installed as necessary.

### **Engine Coolant Temperature Sensor**

The engine coolant temperature sensor is installed as necessary.

### **Transmission Temperature Sensor**

The transmission fluid temperature sensor is installed as necessary.

### **Audible Alarm Buzzer (Optional)**

The optional buzzer is installed as required. A ground is provided at the 12-pin connector pin 6 to activate the buzzer (max current: 300mA). The buzzer will sound when a fault code becomes activated. *(See Table 3 for the Fault Warning Codes list/descriptions on page 15.)*

### **Cables**

There are three cables that connect to the control module. The 8-pin connector is for the remote throttle interface, the 12-pin connector is for the discharge sensor, monitoring, and display interface. The 6-pin connector is for the intake pressure sensor, FRC datalink, and the auxiliary interlock.

## **Controls and Indicators**

All controls and indicators are located on the front of the control module. (Refer to Figure 1.) See Operation and Programming Sections for more information.

### **MENU Button**

Used to access stored data and program features.

### **Oil Pressure LED Display**

Shows engine oil pressure. The LEDs are green when the pressure is within normal limits and red when it is not.

### **CHECK ENGINE LED, STOP ENGINE LED**

Repeats the warnings from the cab.

### **Engine Temperature LED Display**

Shows engine coolant temperature. The LEDs are green when the temperature is within normal limits and red when it is not.

### **Transmission Temperature LED Display**

Shows transmission temperature. The LEDs are green when the temperature is within normal limits and red when it is not.

### **RPM Display**

Shows the current engine RPM in bright red digits. It also shows error codes, stored data, and program features.

### **Battery Voltage LED Display**

Shows battery voltage. The LEDs are green when the voltage is within normal limits and red when it is not.

### **Day/Night Sensor**

Adjusts the brightness of the displays for day or night operations.

### **SILENCE Button**

Press to suppress audio alarms.

### **Message Display**

The message display shows the pressure or RPM setting during normal operations and warning alarms as they occur. It shows the time and date when the throttle ready LED is off. It also shows stored data and program features.

### **THROTTLE READY LED**

This LED is on when the required interlock conditions are met to begin pump operations.



## PRESET Button

Press to change/select a pre-programmed value for pressure or RPM setting.

## IDLE Button

When pressed immediately sets the engine RPM to idle.

## Control Knob

When rotated changes the pressure or RPM setting. The setting increases or decreases proportionally to the speed and direction the control knob is rotated.

## RPM Button

Press to select RPM mode. The LED is on to indicate operation in the RPM mode.

## PRESSURE Button

Press to select pressure mode. The LED is on to indicate operation in the pressure mode.

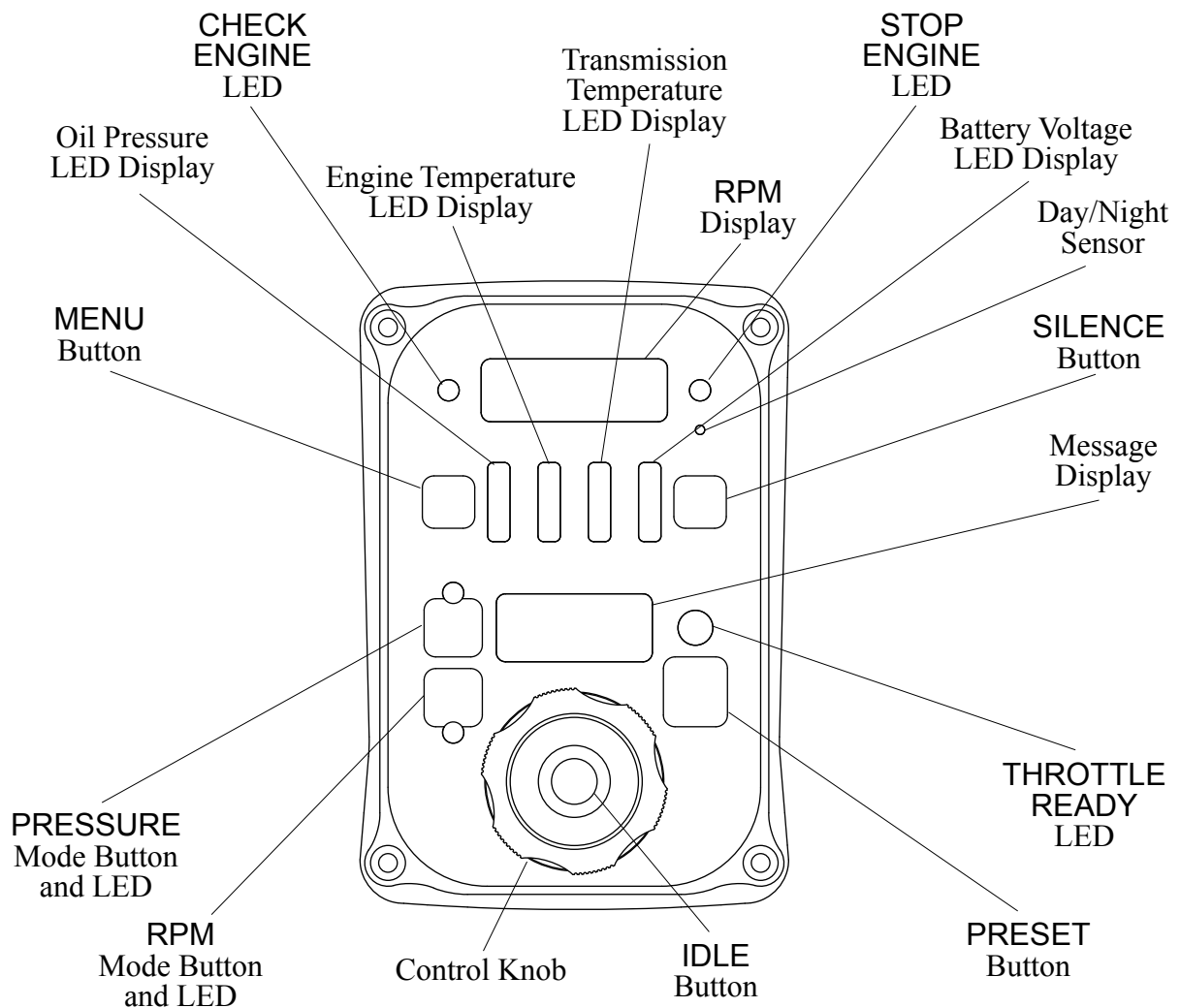

**Figure 1. Controls and Indicators**

---

# INSTALLATION

## Install Control Module

1. Measure and mark mounting location for control module panel cutout and mounting screw holes. Make sure there is clearance behind the panel for the module and cables before cutting holes. Refer to Figure 2 for layout and dimensions.
2. Cut out a 3 1/2 by 5 3/4 inch hole.
3. Drill four holes, clearance or tapped, for 10-32 mounting screws.
4. Place control module in position and secure with screws.
5. Connect cables at rear of the control module. (Refer to Wiring Section.)

Mounting holes are clearance or tapped for 10-32 screws.

Maximum Radius 1/2"

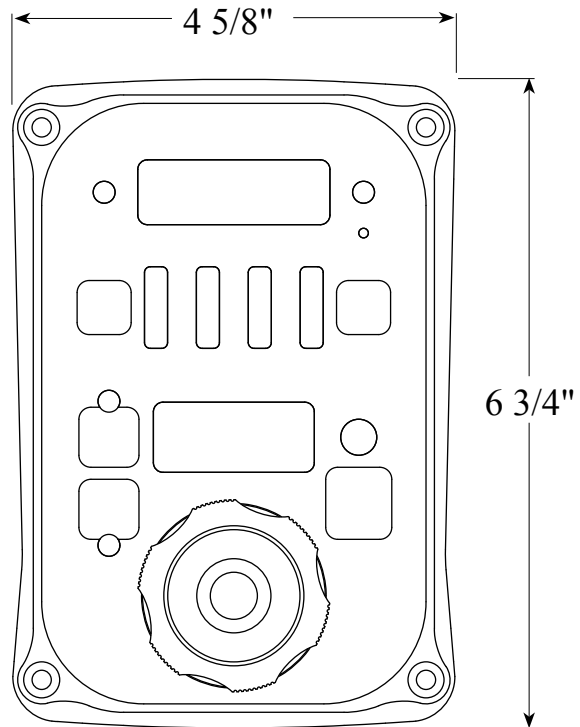
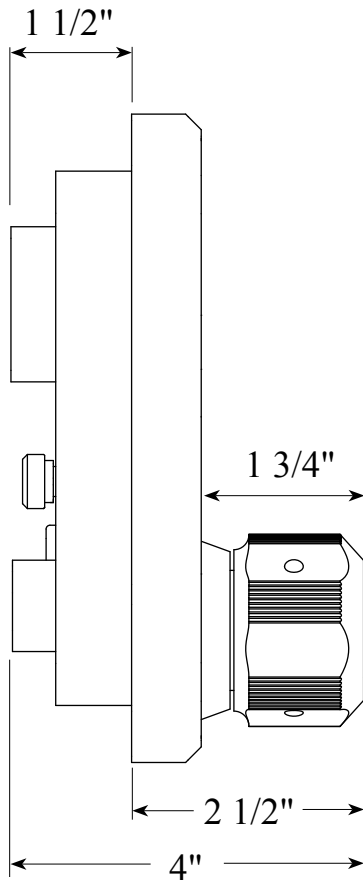
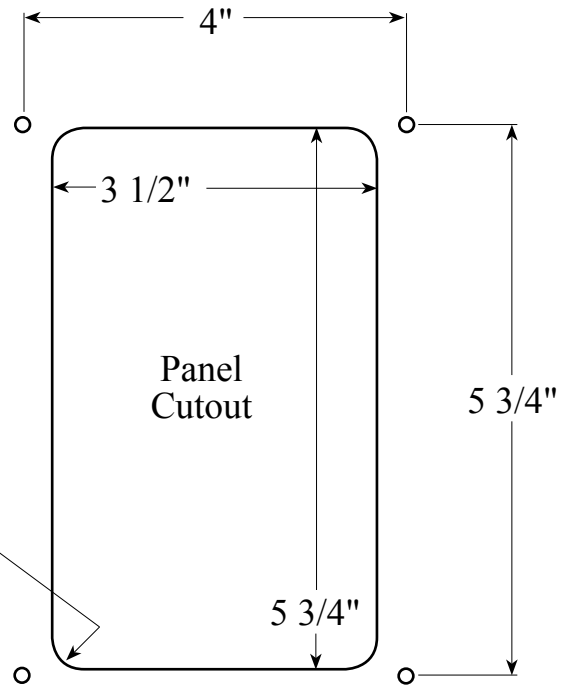

**Figure 2. Control Module Mounting Dimensions**

## Install Pressure Sensor

The discharge pressure sensor is mounted on the pump discharge manifold. If there is a check valve in the discharge side of the pump, mount the discharge sensor before the check valve. The intake pressure sensor is mounted on the pump intake manifold. T-fittings can be used to mount the pressure sensors.

**Note:** Install the pressure sensor upright so that the water in the end of the sensor is able to drain back into the pipe.

1. Screw the sensor into a 1/4-18 NPT hole.

**Caution:** Do not use the main body that houses the electronics to tighten the pressure sensor. Damage to the sensor may occur.

2. Tighten the sensor with a 7/8-inch wrench on the lower hex fitting.
3. Connect the pressure sensor cable from the control module to the pressure sensor. (Refer to Wiring Section.)

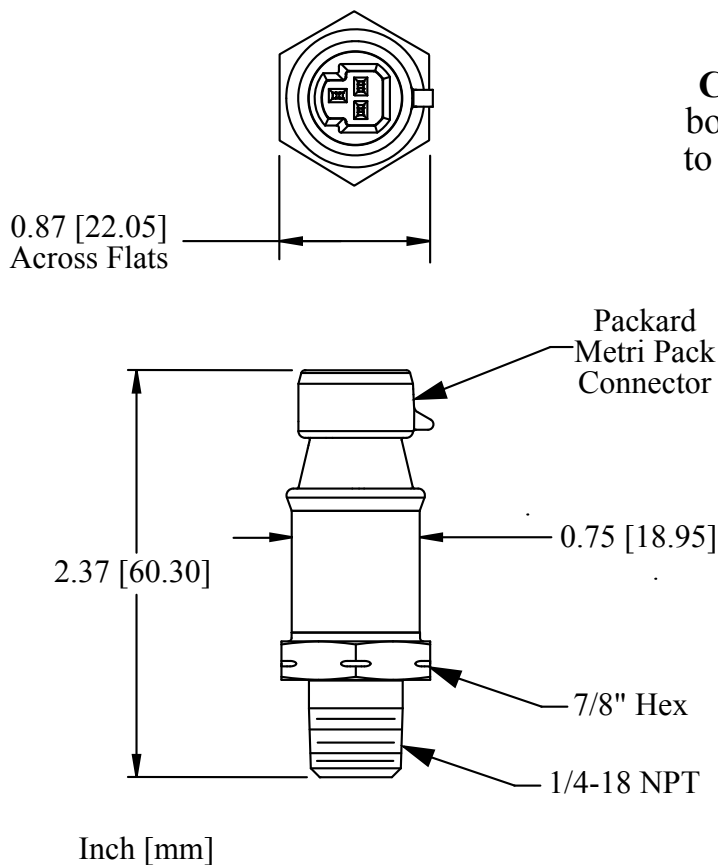

**Caution:** Do not use the main body that houses the electronics to tighten the sensor. Damage to the sensor may occur.

**Caution:** The discharge and intake pressure sensors are the same size. Ensure the correct sensor is installed on the correct manifold. Refer to Table 1.

**Figure 3. Pressure Sensor Dimensions**

---

## Install Engine Sensors

For most engines, the governor receives engine RPM, oil pressure, coolant temperature, and transmission temperature data over the J1939 databus. Some engines do not broadcast this data over the databus and sensors may need to be installed.

**Note:** The PumpBoss may need a programming change for some sensor inputs to be recognized. If the sensor was not ordered as part of the PumpBoss kit you may need to contact FRC technical support for programming information.

The sensors are wired to the 12-pin connector at the rear of the control module. Refer to the Wiring Section.

## Install Buzzer

Pin 6 on the 12-pin connector at the rear of the control module is provided to connect an optional buzzer. Connect the ground side of the buzzer to pin 6. Maximum current through pin 6 is 300 mA. The buzzer ordered from FRC requires a 1-1/8 inch diameter mounting hole. (Refer to the Wiring section.)

## Install High Idle Kit

The high idle is activated when + VDC is provided to pin 7 (High Idle Active Input) of the 12-pin connector and pin 6 (Interlock Input) of the 8-pin connector. Refer to High Idle Wiring.

**Note:** It is important that the connection to the Interlock Input from the High Idle circuit be isolated from the apparatus interlock wiring with the two diodes. **The pump must NOT be engaged when using the high idle function and the THROTTLE READY LED will be off.**

## Install Remote Governor Option

Refer to Install Control Module for dimensions. The remote governor is connected to power, the J1939 CAN Bus, and the FRC datalink. Refer to Wiring Section.

**Note:** Program code P303 SYS TYPE must be set to REMOTE in the remote governor program.

---

# OPERATION

**Note:** When power is applied to the governor the message display shows the Software Program Revision Number for five (5) seconds. It can also be viewed with P101 code, refer to Programming Section.

On power-up the governor is in the pressure mode of operating. The RPM display shows engine RPM, the four LED bar graphs are green indicating readings within normal ranges, and the message display alternates between showing the date and time.

If a monitored function is not within normal parameters the display flashes, the RPM display shows an error or fault warning code and a description shows in the message display. (Refer to Table 2. Error Codes or Table 3. Fault Warning Codes.)

If one of the inputs displayed by the LED bar graphs is not within normal range the LEDs will be red.

When all necessary throttle enables are active and the interlock circuit is complete, the THROTTLE READY LED comes on and the governor is ready to control the engine RPM. The control signal is set at idle regardless of the control knob position.

## Controls

### Control Knob

The control knob is used to adjust pressure and RPM settings. The governor senses how fast and in what direction the control knob is rotated and sends a signal to the ECM to increase or decrease the engine RPM proportionally.

If the control knob is rotated quickly; the engine RPM changes quickly.

If the control knob is rotated slowly; the engine RPM changes slowly.

- Rotate the control knob clockwise\* to increase engine RPM.
- Rotate the control knob counterclockwise\* to decrease engine RPM.
- Press the red IDLE button to immediately return the engine to idle.

**\*NOTE:** Opposite knob rotation option is available to increase/decrease the engine RPM.

## Error Codes and Fault Warnings

### Table 2. Error Codes

RPM Display	Message Display	Probable Cause Note: Not all inputs are used for all engines.
<b>E01</b>	NO DATA	>J1939 CAN bus cable not connected / connected to wrong port >Broken wire / bad connector contact on cable
<b>E02</b>	NO RPM	Engine RPM not detected >Data cable not connected / connected to wrong port >Engine not running / ignition key on >Broken wire / bad connector contact on alternator cable
<b>E04</b>	NO OIL SENSOR	No Engine Oil Pressure Data Detected (w/separate sensor input) >Sensor cable not connected >Broken wire / bad connector contact on sensor cable >Defective pressure sensor
<b>E05</b>	NO D. PSR SENSOR	No Discharge Pressure Sensor Detected >Sensor cable not connected >Broken wire / bad connector contact on sensor cable >Defective pressure sensor
<b>E06</b>	NO I. PSR SENSOR	No Intake Pressure Sensor Detected >Sensor cable not connected >Broken wire / bad connector contact on sensor cable >Defective pressure sensor
<b>E07</b>	NO ENG T SENSOR	No Coolant Temperature Data Detected (w/separate sensor input) >Sensor cable not connected >Broken wire / bad connector contact on sensor cable >Defective temperature sensor
<b>E16</b>	NO FRC DATALINK	>FRC datalink cable not connected / connected to wrong port >Broken wire / bad connector contact on cable

**Note:** E5 and E6 show on a remote governor not programmed correctly (code P303).

### Table 3. Fault Warning Codes

RPM Display	Message Display	Description	Factory Default Setting
<b>F01</b>	HI BATT VOLTAGE	High Battery Voltage	15.5 V
<b>F02</b>	LOW BATT VOLTAGE	Low Battery Voltage	11.8 V*
<b>F03</b>	HI TRANS TEMP	High Transmission Temperature	300 °F
<b>F04</b>	LOW OIL PRESSURE	Low Engine Oil Pressure	8 PSI**
<b>F05</b>	DPFR	Discharge Sensor High Voltage	
<b>F06</b>	IPFR	Intake Sensor High Voltage	
<b>F07</b>	HI ENG TEMP	High Engine Coolant Temperature	220 °F**
<b>F08</b>	NO WATER	Out of Water Mode	
<b>F09</b>	ENG NOT RESPOND	Engine Does Not Respond	

\* 11.8 engine running, 11.7 engine off.

\*\* J1939 compliant—engine ECM will issue this warning.

---

## Pressure Mode Operation

In the pressure mode of operation the **PRESSURE LED** is on. The governor maintains a constant discharge pressure within system capabilities. It adjusts the engine RPM automatically to compensate for variations in pressure.

There is a maximum engine RPM programmed in the governor for pressure mode. If the engine reaches the programmed maximum RPM the message display flashes **MAX RPM / OPERATOR** and the engine RPM is not allowed to go higher. (The maximum engine RPM is normally set at 2100 and is programmable.)

If the discharge pressure is below 15 PSI when the operator increases the pressure setting, the display shows **PRESS LOW**.

**Note:** When changing from RPM to pressure mode during operations, hold the **PRESSURE** button for 3 seconds. The pressure setting is the pressure that the pump was operating at in RPM mode.

1. Press **PRESSURE** button to select the pressure mode.

Result: **PRESSURE LED** goes on.

2. Press **PRESET** and/or rotate control knob to select pressure setting.

Result: Message display shows pressure setting, engine RPM changes.

3. Press **IDLE** button after operations to set engine to idle RPM.

Result: Message display shows **IDLE ENGINE**, engine at idle RPM.

### Opening/Closing Discharge Valves

In pressure mode the governor maintains the pressure setting regardless of the number of discharge lines that are opened or closed providing there is sufficient water supplied. As lines are opened the discharge pressure starts to drop and the governor raises the engine RPM to maintain the required pressure. As lines are closed and the discharge pressure starts to rise, the governor lowers the engine RPM to maintain the required pressure.

### Operating From a Pressurized Supply

When operating from a pressurized water source (hydrant, in-relay, etc.), the intake supply should be routed through a valve. If the pressurized source fails, the pump operator can close the valve. This eliminates the chance of sharp pressure spikes at the pump intake if the supply is resumed suddenly. The operator must open this valve slowly when the supply is resumed to help prevent pressure spikes.



---

## Running Away From Water, Low Water, or No Supply Water

There are situations during pump operations when there may be low or no supply water. This can be due to an empty water tank, a problem on the intake line, air in the pump, changing the water source, or an insufficient water supply.

The governor constantly monitors discharge pressure and compares it to engine RPM. It is programmed to limit RPM increases when conditions arise that fall outside of normal operating parameters.

**Running Away From Water:** If the discharge pressure starts dropping while operating in pressure mode, the governor increases the engine RPM and attempts to maintain the selected pressure setting. If pressure drops and an increase in RPM does not bring the pressure back up, the governor recognizes this as a running away from water condition. When this condition occurs the governor switches to the RPM limit mode and controls the engine RPM accordingly.

**RPM Limit Mode:** When the RPM limit mode is in effect the **PRESSURE** LED stays on. To alert the operator the **RPM** LED and the **RPM** display flash, and the message display flashes **OPERATOR / RPM LIMIT**. In this mode the pressure setting does not change and the **PRESET** button is disabled. When the pressure comes back up to the selected pressure setting, the RPM limit mode is canceled and the governor switches to normal operation in pressure mode at the selected pressure.

In some cases the pressure may not come back up but remains at a level above 45 PSI. In the RPM limit mode, the governor behaves like a manual throttle and the operator can raise or lower the engine RPM by rotating the control knob. If the RPM is manually lowered to a point where the pump is not running away from water and pressure is stable, the RPM limit mode is canceled. The governor switches to normal operation in pressure mode with the current discharge pressure as the new pressure setting.

If the engine is set to idle using the **IDLE** button, the governor comes out of RPM Limit Mode and cancels the pressure setting.

**Low Water Cycle:** If the discharge pressure is below 45 PSI, but stays above 15 PSI, the governor enters a low water cycle and the message display flashes **LO WATER**. It sets the engine at 1100 RPM. If the pressure does not rise above 45 PSI in 7 seconds, the governor sets the engine RPM at idle. The governor repeats the low water cycle as long as the discharge pressure is between 15 and 45 PSI. When the pressure rises above 45 PSI the governor resumes normal operation. (The values for RPM and PSI in the low water cycle are programmable and may vary for some engine/pump combinations.)

**No Supply Water:** If the discharge pressure is below 15 PSI, the engine RPM is set at idle and the message display flashes **NO WATER**. If, within 3 minutes, the discharge pressure rises above 15 PSI the governor enters the low water cycle. If the discharge pressure does not rise above 15 PSI within 3 minutes, the governor switches to idle mode and cancels the pressure setting. To restart pump operations, the operator must take action (press **PRESET** and/or rotate control knob to select pressure setting).

## RPM Mode Operation

In the RPM mode of operation the RPM LED is on. The governor maintains a constant engine RPM.

The pump discharge pressure can vary but, as a safety feature, the governor limits the increase in pressure to 30 PSI over the last established PSI value. As the discharge pressure approaches this limit the governor automatically lowers the RPM to prevent a high pressure surge. The RPM LED blinks as the governor sets a lower RPM. This lower RPM will be the new operating RPM setting.

**Note:** When changing from pressure to RPM mode during operations, hold the RPM button for 3 seconds. The RPM setting is the RPM that the pump was operating at in pressure mode.

1. Press RPM button to select RPM mode.

Result: RPM LED goes on.

2. Press PRESET and/or rotate control knob to select RPM setting.

Result: Message display shows RPM setting, engine RPM changes.

3. Press IDLE button after operations to bring engine to idle RPM.

Result: Message display shows IDLE ENGINE, engine at idle RPM.

---

## Switching Between Operating Modes

- No variation in discharge pressure or RPM occurs when changing between pressure and RPM modes.
- When changing to RPM mode, the RPM setting is the RPM that the pump was operating at in pressure mode.
- When changing to pressure mode the pressure setting is the pressure that the pump was operating at in RPM mode.

When the engine is at idle RPM:

Press the mode button and the governor changes modes immediately.

When the engine RPM is above idle:

Press and hold the mode button for 3 seconds and the governor changes modes. (This is to avoid an accidental change over if the buttons get bumped.)

## Pump Discharge Pressure is High at Engine Idle

Once the governor has set the engine RPM at idle, it can do no more to reduce discharge pressures. To reduce discharge pressure the pump operator can gate incoming water, reduce pressure at the intake relief valve, gate discharges, or disable the pump.

## RPM Limit with Discharge Pressure Less than 100 PSI

The level II programming code P221 sets the maximum RPM when the pump is operating with a discharge pressure less than 100 PSI. The factory set default is for code P221 is 1500. Access to level II programming required a password. Contact FRC if this default limit needs to be changed.

## Remote Governor Option

The remote governor option duplicates the primary governor functions.

The remote governor control module is required to be programmed as a remote (program code P303). If error codes E5 and E6 show on power up, check the programming.

## Detailed Information

The four LED bar graphs provide constant display of safe operating ranges for engine oil pressure, engine coolant temperature, transmission temperature, and battery voltage. They do not show exact numbers or units of measure. Detailed information is shown in the message display when the MENU button is pressed. Engine hours and pump hours are also shown.

### Show Detailed Information

**Note:** Detailed information is a display only mode and no changes can be made to the data.

The MENU button allows the operator to gain access to detailed information. Each time the MENU button is pressed the display scrolls to show the next value.

The message display indicates the following:

ENG TEMP	### °F	(programmable for °C)
ENG OIL	### PSI	(programmable for kPa or Bar)
BATT VDC	##.# V	(programmable for 12V or 24V)
ENG HRS	#####	
PUMP HRS	#####	
TRANS T.	### °F	(programmable for °C)
D.SENSOR	##### PSI	(programmable for kPa or Bar)
I.SENSOR	##### PSI	(programmable for kPa or Bar)

The message display reverts to normal operation after 20 seconds if no buttons are pressed. When a button other than the MENU button is pressed, the display immediately reverts to normal operation. The SILENCE button should be used during operations.

## High-Idle

The governor programming includes a high-idle function. To activate the high-idle set all interlocks as called for by local SOP (normally this would include the transmission in neutral and the parking brake on). Set the High-Idle switch to ON.

**Note:** The pump must NOT be engaged when using the high-idle function and the THROTTLE READY LED will be off.

### Change High-Idle Setting

**Note:** The high-idle is set at about 1000 RPM at the factory. (This value varies depending on the specific engine.)

1. With the engine running, set the high-idle switch to ON.

Result: Engine goes to high idle RPM.

2. Press and hold PRESET button for 3 seconds.  
Result: RPM display flashes and shows the high-idle setting.
3. Keep pressing the PRESET button and rotate control knob to desired RPM.
4. Release PRESET button to store the new high idle setting.

## Preset Settings (Pressure or RPM)

The preset button allows the operator to go to a pre-programmed pressure or RPM setting during operations. The preset value shows in the message display. This procedure is to change the pre-programmed setting. (Factory default preset maximum limits are: pressure = 200 PSI; RPM = 1500.)

**Note:** The engine must be running and the pump engaged interlock circuit must be closed (the THROTTLE READY LED **must be on**).

1. Press IDLE button.  
Result: Engine goes to idle RPM
2. Press PRESSURE or RPM button to select the setting to be changed.  
Result: LED indicator goes on for mode selected.

**Note:** The message display must show IDLE ENGINE before changing the preset.

3. Press and hold PRESET button. (Continue to hold through step 4.)  
Result: Message display shows PRESET. After 5 seconds the current setting flashes. The preset value is set at this time but is not allowed to exceed the factory default limits of pressure = 200; RPM = 1500.

**Note:** If the factory default limits are to be exceeded, step 3a. must be included, if not proceed with step 4.

- 3a. Press and hold the SILENCE button for 5 seconds to unlock the default limits.  
Result: Message display shows UNLOCKED. Release the SILENCE button (continue to hold the PRESET button). The preset value is now allowed to exceed the default limit.

4. Rotate control knob to change preset setting.
5. Release PRESET button.  
Result: The new preset value is programmed. Message display shows IDLE ENGINE.

# PROGRAMMING

The following program functions are always available to view and change:

P101 - Software Program Revision Number - Read Only

P102 - Product Manufacturing Date - Read Only

P103 - Set Current Date - Read/Write

P104 - Set Current Time - Read/Write

P105 - Retrieve Fault Codes - Read Only

P106 - Engine Type Code - Read Only

## Access Program Features

**Note:** When the program (P) code is flashing in the RPM display, press the **PRESSURE** or **RPM** button to scroll through the P-codes or press the **SILENCE** button to exit the programming mode.

1. Press the **SILENCE** button and hold it until the RPM display shows four dashes `----` and the message display shows `ENTER--- CODE`. Release the button.

Result: `P 1 0 1` flashes in the RPM display. The message display shows the program revision number `PROG REV V500.03`.

2. Press the **PRESSURE** button.

Result: `P 1 0 2` flashes in the RPM display. The message display shows the manufacturing date `MFG DATE 16JAN'15` (ddmmm'yy).

3. Press the **PRESSURE** button.

Result: `P 1 0 3` flashes in the RPM display. The message display shows the current date `SET DATE 16JAN'15`.

4. To Change the Date: (If not, go to step 5.)

- a. Press the **MENU** button.

Result: `P 1 0 3` stops flashing. The message display shows the current date with the year flashing.

- b. Press the **PRESSURE** or **RPM** button to change the year.

- c. Press the **MENU** button.

Result: The month flashes.

- d. Press the **PRESSURE** or **RPM** button to change the month.

- e. Press the **MENU** button.

Result: The day flashes.

- f. Press the **PRESSURE** or **RPM** button to change the day.

- g. Press and hold the **SILENCE** button to store the new date.

Result: `P 1 0 4` flashes in the RPM display. The message display shows `SET TIME 10:30AM`. Go to step 6.

5. Press the **PRESSURE** button.

Result: **P 1 0 4** flashes in the RPM display. The message display shows **SET TIME 10:30AM** .

6. To Change the Time: (If not, go to step 7.)

- a. Press the **MENU** button.

Result: **P 1 0 4** stops flashing. The message display shows the current time with the **AM** or **PM** flashing.

- b. Press the **PRESSURE** or **RPM** button to change **AM** or **PM**.

- c. Press the **MENU** button.

Result: The minute flashes.

- d. Press the **PRESSURE** or **RPM** button to change the minutes.

- e. Press the **MENU** button.

Result: The hour flashes.

- f. Press the **PRESSURE** or **RPM** button to change the hours.

- g. Press and hold the **SILENCE** button to store new time.

Result: **P 1 0 5** flashes in the RPM display. The message display shows **NO WARNING** or **LOGGED DATA**. Go to step 8.

7. Press the **PRESSURE** button.

Result: **P 1 0 5** flashes in the RPM display. The message display shows **NO WARNING** or **LOGGED DATA**.

8. Press the **MENU** button when it shows **LOGGED DATA** or go to step 9.

Result: **5 1** flashes in the RPM display. The fault, date, and time that the fault code was recorded shows in the message display.

- a. To scroll through the logged fault code data, press the **PRESSURE** or **RPM** button.

- b. Press the **SILENCE** button to exit viewing logged data.

9. Press the **PRESSURE** button.

Result: **P 1 0 6** flashes in the RPM display. The message display shows the engine type code that is set in the program. (Refer to the Engine Code Reference Table, Document Number XE-ECRTREF01-R0A.)

- 10 Press the **PRESSURE** or **RPM** button to scroll through the P-codes or press the **SILENCE** button to exit the programming mode.

---

## Access Password Protected Programs

The following program functions are available to view and change after the password code has been entered:

### Calibration Password Code 1111

C1 - Discharge Pressure Sensor Zero Calibration

C2 - Intake Pressure Sensor Zero Calibration

C3 - Engine RPM Calibration

Refer to Calibration Section.

### Operator Password Code 1221

Operator Password Code 1221 allows the parameter settings of limited program functions to be changed. Refer to Table 4. Operator Password Protected Program Functions.

P318 - RPM Limit for Pressure Control (Factory default is 2100.)

### Enter Password Code

**Note:** To exit the programming mode, press the **SILENCE** button when the program code flashes in the **RPM** display.

1. Press the **SILENCE** button and hold it until the **RPM** display shows four dashes – – – – and the message display shows **ENTER--- CODE**. Release the button.
2. Press the **MENU** button within three seconds. The message display shows **CODE ENTRY**. The **RPM** display shows the number 1000. Each time the **MENU** button is pressed the first digit increments by 1. Set the first digit to the desired number.
3. Press the **SILENCE** button to move the cursor to the next digit. Press the **MENU** button to change the digit.
4. Repeat step 3 and enter the password code. (Calibration password is 1111. Operator password is 1221.)

Result: When a correct password code is entered **C 1** for calibration or **P 3 1 8** flashes in the **RPM** display.

5. Press the **PRESSURE** or **RPM** button when the program code is flashing to scroll through the program codes.



6. Press the **MENU** button to enter the programming mode to view and change parameter settings.

Result: The program code stops flashing. The message display shows a selectable option or a numerical value.

7. Press the **MENU** button to change a selectable option or the **PRESSURE** or **RPM** button to change a numerical value.
8. Press the **SILENCE** button to save the changes and exit the programming mode.

Result: The program code advances to the next code and flashes.

9. Repeat steps 5 through 8 as necessary.
10. Press the **SILENCE** button when the program code is flashing to exit.

**Table 4. Operator Password Protected Program Functions**

Values shown are standard factory default and may vary with engine type selected.

CODE	DESCRIPTION	MESSAGE DISPLAY	Press MENU button to select; change value with PRESSURE or RPM
P318	RPM limit for pressure control	MAX RPM LIMIT <> 2100	

## CALIBRATION

Three programs are available after the calibration password code has been entered:

C1 - Discharge Pressure Sensor Zero Calibration

C2 - Intake Pressure Sensor Zero Calibration

C3 - Engine RPM Calibration

Refer to Table 5. Calibration Codes Quick Reference Chart.

### Enter Calibration Password Code 1111

**Note:** To exit the programming mode, press the SILENCE button when the program code flashes in the RPM display.

1. Enter the password code 1111. (Refer to Programming Section.)

Result: When the correct password code is entered C 1 flashes in the RPM display. The message display shows D.PSI.

2. Press the PRESSURE or RPM buttons when the program (C) code is flashing to scroll through the program codes.

Refer to specific calibration section for detailed procedures.

**Note:** If there is a failure during calibration the message display shows SENSOR PROBLEM.

3. Press the SILENCE button when the program (C) code is flashing to exit.

**Table 5. Calibration Codes Quick Reference Chart**

CODE	DESCRIPTION	MESSAGE DISPLAY	Press MENU Button Again	Press MENU Button Again
C1	Discharge Pressure Sensor Zero Calibration	D.PSI	D.PSI SET P=0?	D.PSI D.PSI=0
C2	Intake Pressure Sensor Zero Calibration	I.PSI	I.PSI SET P=0?	I.PSI I.PSI=0
C3	Engine RPM Calibration	CAL. ENG RPM	SET RPM XXXX	

---

## Pump Pressure Sensor (Code C1 and C2)

The program for the pump pressure sensor(s) is self-calibrating. There are no adjustments that can be made to the sensors. When the calibration program is activated the signal from the sensor(s) is assumed to be 0 PSI.

**Note:** If there is pressure in the plumbing where the sensor is mounted this causes the program to be calibrated to a false 0. To prevent false zeroing, drain the pump and plumbing to ensure there is no residual pressure before running the calibration procedure.

1. Apply power to the display module.
2. Enter the calibration password.
3. Scroll to code C1 D.PSI or C2 I.PSI.
4. Press the MENU button SET P=0? flashes.
5. Press the MENU button again to set at 0. D.PSI=0 or I.PSI=0 flashes.
6. Press and hold the SILENCE button for 3 seconds to save the setting into memory.
7. Press the SILENCE button when the program (C) code is flashing to exit calibration. Press the MENU button to enter the next program. Press the PRESSURE or RPM buttons to scroll through program codes.

## Engine RPM (Code C3)

This code is not applicable for engines with the J1939 CAN connected. To perform the following calibration, a reference tachometer is needed to verify the correct engine RPM.

1. Apply power to the display module.
2. Enter the calibration password.
3. Scroll to code C3 CAL. ENG RPM.
4. Press the MENU button to show SET RPM.  
Result: Flashing digit is ready to be changed.
5. Set the RPM to match the reference RPM. Press the PRESSURE or RPM buttons to change the value. Press the MENU button to change the digit.
6. Press the SILENCE button to save the setting into memory.
7. Press the SILENCE button when the program (C) code is flashing to exit calibration. Press the MENU button to enter the next program. Press the PRESSURE or RPM buttons to scroll through program codes.

# WIRING

The following figures include the schematics, wiring diagrams, block diagrams, and cables for the governor.

## Connectors and Cables

For most engines the governor receives engine RPM, oil pressure, and coolant temperature data over the J1939 data link from the ECM. Some engines do not broadcast this data over the data link and sensors may need to be installed.

When a remote governor is installed ensure that the control module program code P303 is set to REMOTE. Refer to Figure 5 for wiring details.

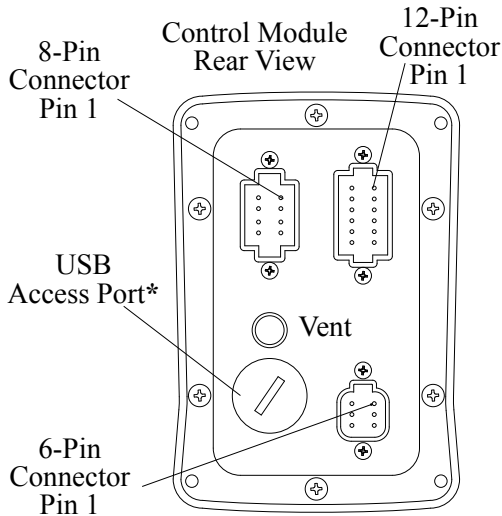

**\*NOTE:** If opened, USB access port plug must be tightened to a torque of 8-10 in-lbs. Exceeding this torque value can result in damage to its water seal capability.  
**Warning:** Flange may not fully bottom out.

8 Pin Connector/Cable		
Pin	Wire Color	Description
1	Red	Supply Power (12/24 VDC)
2	Black	Ground
3	Orange	+5 VDC Reference From ECM
4	White	Throttle Signal To ECM
5	Green	Signal Return From ECM
6	Yellow	Interlock Input (+ VDC)
7	Blue	Throttle Enable Signal Output
8	Brown	Foot Pedal Signal Input

**Notes:**

- Not all wires are used for all engines. Refer to the engine specific wiring diagram for interface connections.
- An adapter and cable assembly replaces the basic 8-pin cable when connecting the governor to a GMC engine. Refer to the engine specific wiring diagram.

12 Pin Connector/Cable		
Pin	Wire Color	Description
1	Red	+ 5 VDC Discharge Pressure Sensor
2	Black	Ground Discharge Pressure Sensor
3	White	Signal Discharge Pressure Sensor
4	Blue	Engine Oil Press. Sensor Signal
5	Orange	Engine Temp. Sensor Signal
6	Brown	Buzzer Ground (300mA)
7	Violet	High Idle Active Input (+ VDC)
8	White	J1939 CAN (Shield)
9	Black	J1939 CAN (-)
10	Red	J1939 CAN (+)
11	Green	Transmission Temp. Sensor Signal
12	Yellow	RPM Signal

**Notes:**

- Not all wires are used for all engines.
- High idle is not available for GMC.
- When using an FRC provided engine sensor cable, the red wire is sensor signal and the black wire connects to a ground.

**Figure 4. PBA Connectors**

### 6 Pin Connector/Cable

Pin	Wire Color	Description
1	Red	+ 5 VDC Intake Pressure Sensor
2	Black	Ground Intake Pressure Sensor
3	White	Signal Intake Pressure Sensor
4	Green	FRC Datalink (-)
5	Yellow	FRC Datalink (+)
6	N/C	

**Notes:**  
 - Pump intake sensor on PBA400 only.

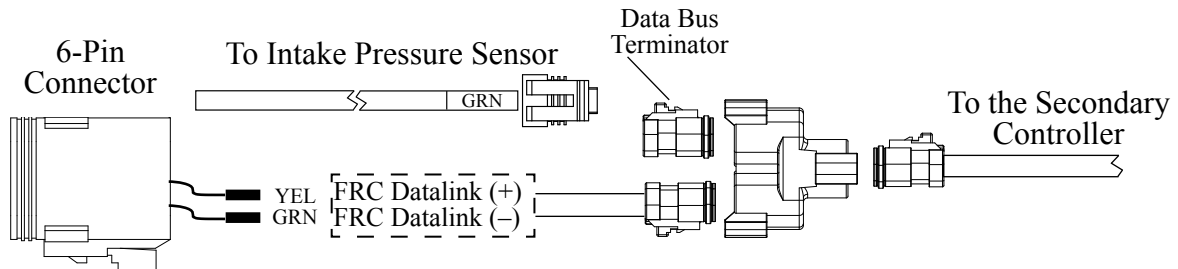

## Secondary Controller, Cables and Connections

### Secondary Controller

12, 8 and 6 Pin Connector Wiring

**Note:** The program code P303 must be set to **REMOTE** on the Secondary Controller control module.

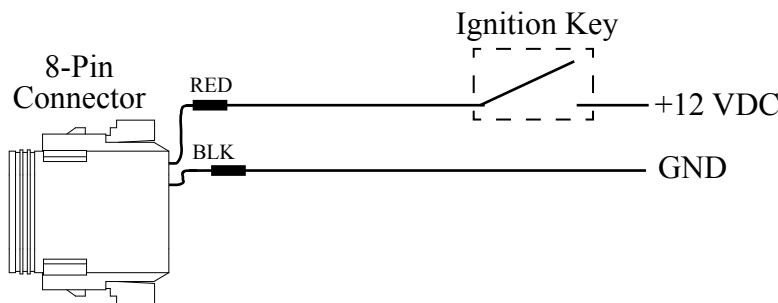
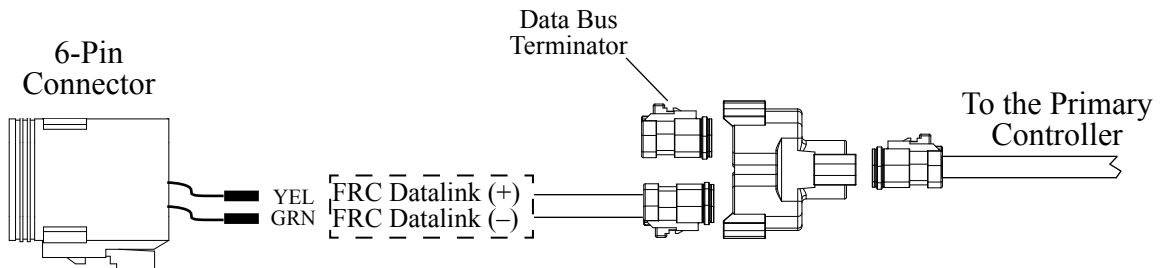

**NOTE:** Terminating resistor and adapters are included in the kit for connection to the primary display; no other wires are required for remote operation.

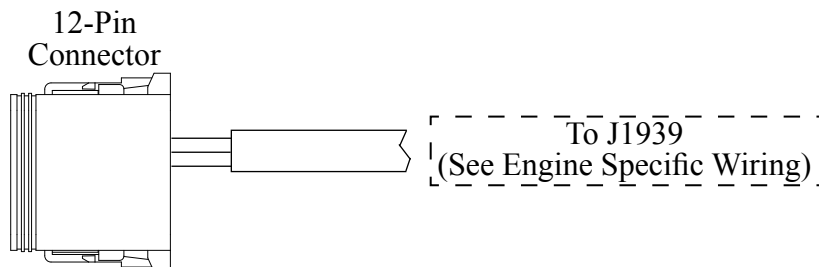

**Figure 5. PBA Connector Wiring**

# Pressure Sensor

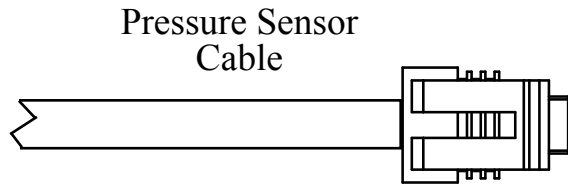

Pressure Sensor Cable 3-Pin Connector	
Pin/Wire	Description
A/Black	Ground
B/Red	Supply Voltage
C/White	Signal

Pressure Sensor  
Top View

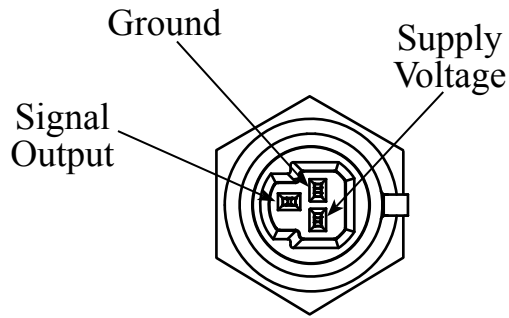

Pressure Sensor  
Side View

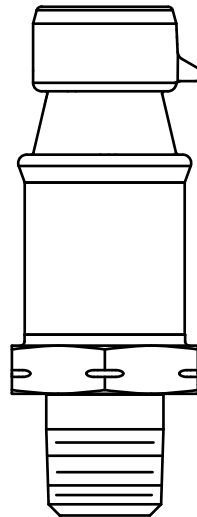

**Caution:** The discharge and intake pressure sensors are the same size. Ensure the correct sensor is installed on the correct manifold. Refer to Table 1.

**Figure 6. Pressure Sensor Wiring**

# Common OEM Diagnostic Connector

Typical 9-pin Deutsch Diagnostic Connector.  
Commonly found under the driver side dashboard.

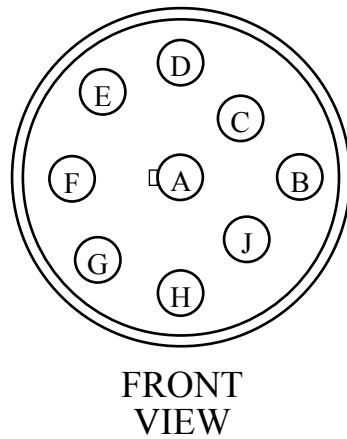

<b>9-Pin Connector</b>	
<u>Pin</u>	<u>Description</u>
A	BATTERY GROUND
B	+12 VDC
C	J1939 CAN (+)
D	J1939 CAN (-)
E	J1939 SHIELD
F	J1587 DATA BUS (+)
G	J1587 DATA BUS (-)
H	PLUG
J	PLUG

**Figure 7. Common OEM 9-Pin Diagnostic Connector**

# Cummins Harness Connections

## Interface Information

For use on 2004 or newer engines.

The governor is designed to control engine throttle directly over the SAE J1939 databus.

If the PUMPBOSS is being used on a COMMERCIAL CHASSIS with a Cummins Engine, ENSURE that the Cummins Engine EMERGENCY VEHICLE CALIBRATION is programmed in the engine ECM for the PUMPBOSS to work.

**Note:** Refer to Figure 4. PBA Connector Wiring for power and interlock wire connections.

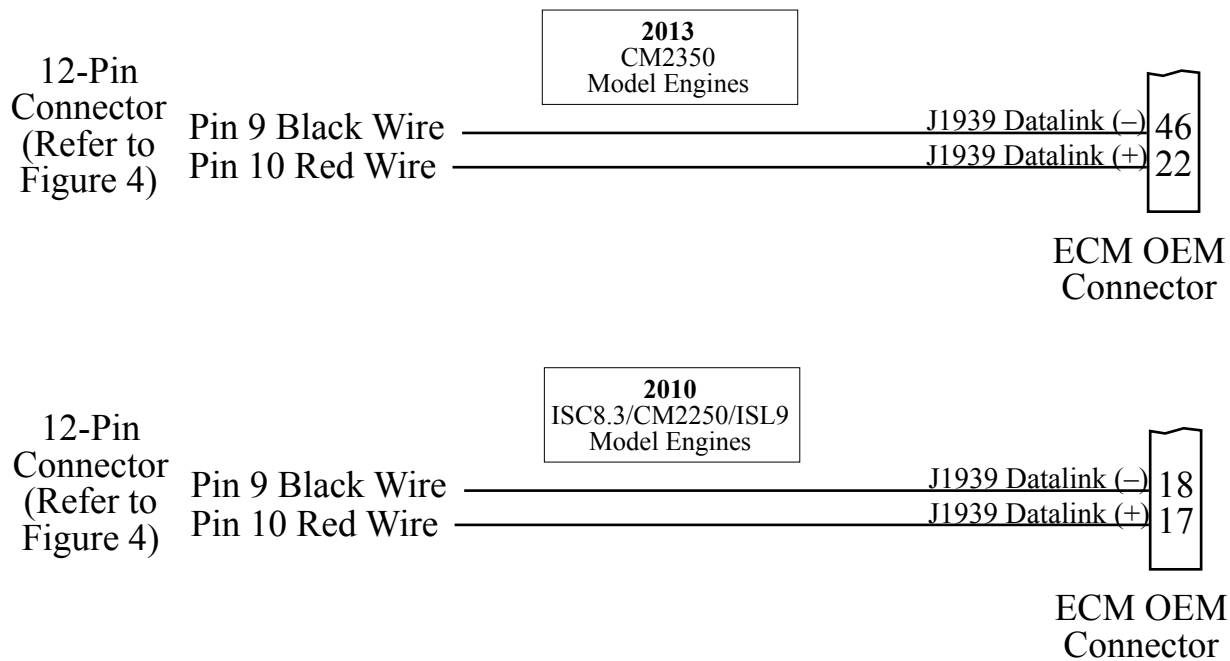

**Figure 8. Cummins PBA401 Wiring**



# Detroit Diesel Harness Connections

## Interface Information.

The governor is designed to control engine throttle directly over the SAE J1939 databus. Remote throttle does not need to be enabled in the ECM.

**Note:** Refer to Figure 4. PBA Connector Wiring for power and interlock connections.

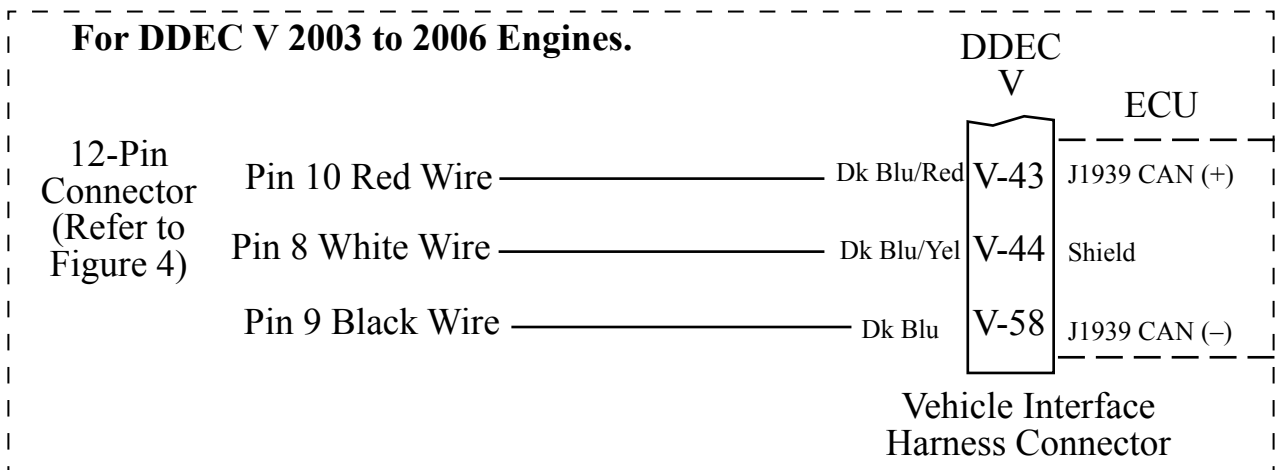
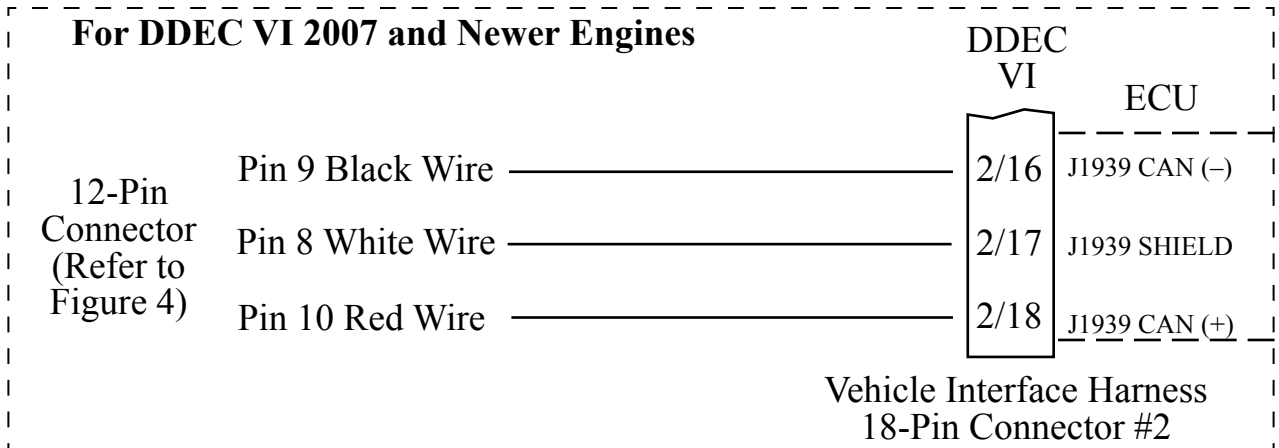

**Figure 9. Detroit Diesel PBA402 Wiring**

# Navistar Harness Connections

## Interface Information

The ECM must be programmed for remote variable throttle operation.

**Note:** Check the governor engine code to verify the program setting (for J1939 control use 4C and for voltage control use 4D). Wire accordingly or change the code.

**Note:** Refer to Figure 4. PBA Connector Wiring for power and interlock wire connections.

### J1939 CAN Bus Control 12VXY 2010 and Newer MAXXFORCE 11 and 13 Engines

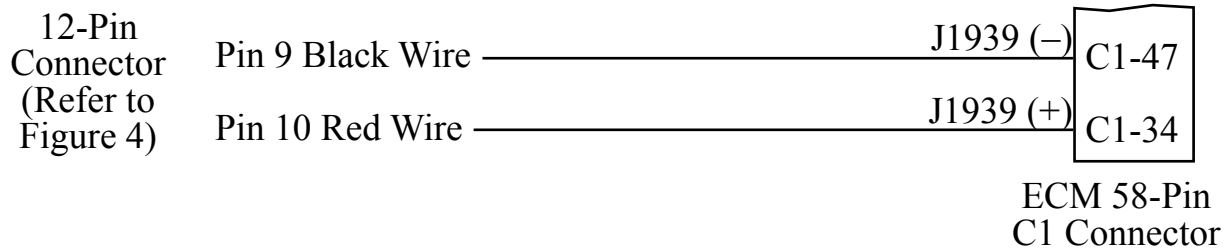

### Voltage Control Post 2007 MAXXFORCE 7, DT, 9, 10, 11, and 13 Engines

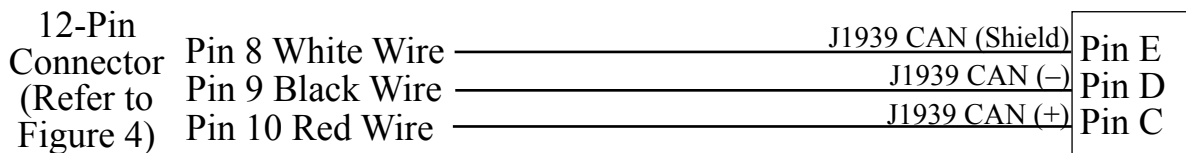
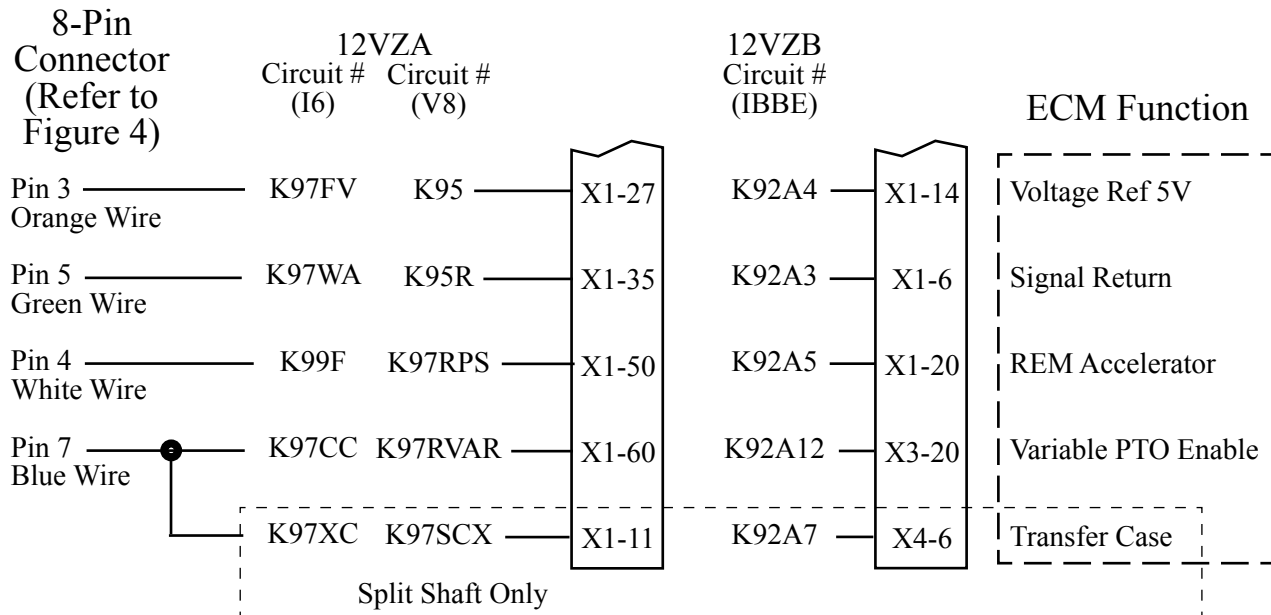

EST Connector

**Figure 10. Navistar PBA404 Wiring**

# Navistar / International Chassis Harness Connections

## Interface Information

**Note:** This function is not available on custom chassis, refer to Figure 10. Navistar PBA Wiring.

Vehicles must be equipped with an Electronic System Controller (ESC) and have the Body Builder J1939 Datalink available.

Remote Engine Speed must be set to ON (Feature Code 0595AHA)

Connect the Body Builder J1939 Datalink to the FRC Datalink for engine control as shown below.

**Note:** Refer to Figure 4. PBA Connector Wiring for power and interlock wire connections.

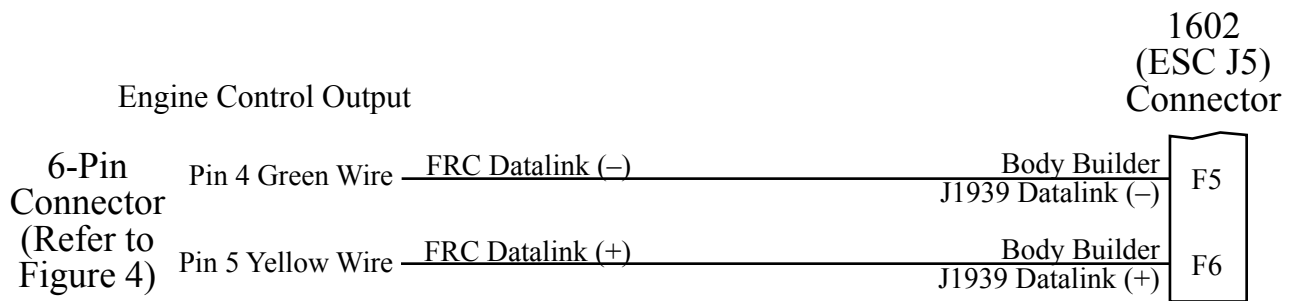

**Note:** The Body Builder J1939 Datalink is for engine control, the J1939 CAN Bus provides engine information to the governor.

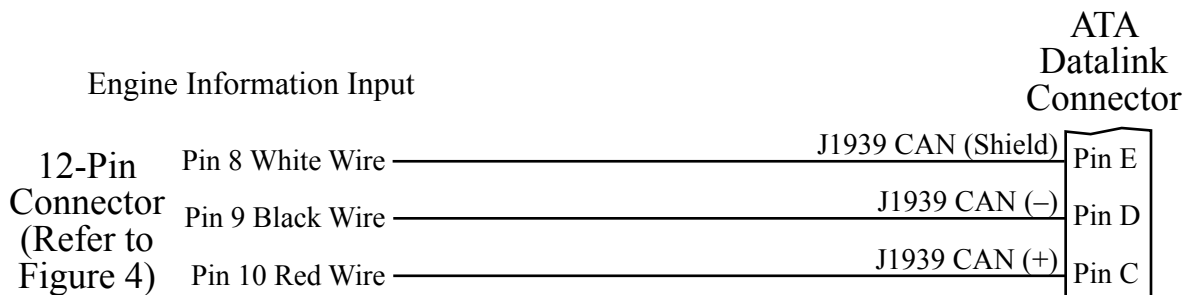

**Figure 11. Navistar/International Chassis PBA404 Wiring**

# Caterpillar Harness Connections

## Interface Information

The parameter settings for PTO Configuration is programmed to Remote Throttle or Remote Throttle with J1939 Speed Command.

ECM software with a Personality Module release date of May08 for C7, C9, C13, C15 engines, has the Remote Throttle with J1939 Speed Command setting available. This setting allows the engine speed to be controlled during PTO operations by a J1939 compliant device.

Refer to an authorized dealer to program one of these options.

## C7, C9, C10, C11, C12, C13, C15 Engine Interface

Engines with 70-pin OEM connector.

**Note:** Refer to Figure 4. PBA Connector Wiring for power and interlock wire connections.

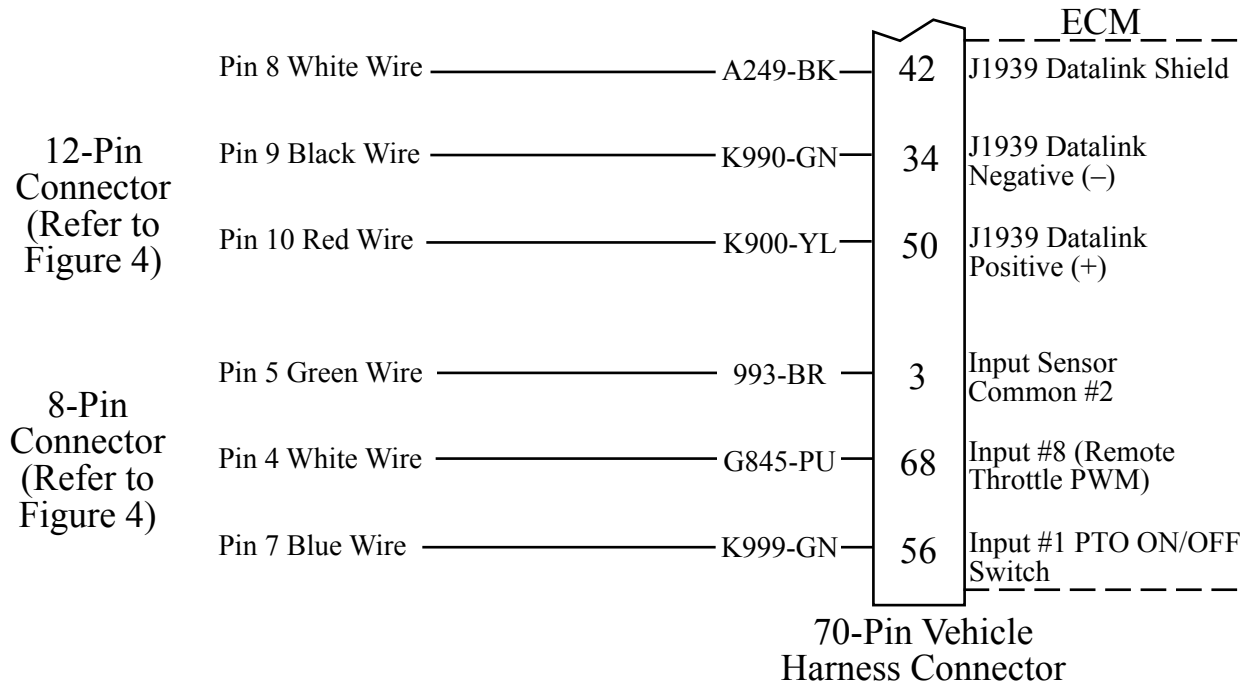

**Figure 12. Caterpillar PBA405 Wiring**

# Ford Harness Connections

## J1939 Interface Information

A J1939 CAN input is required to provide engine information to the governor. The Ford vehicle CAN Bus information needs to be interpreted. A J1939 Translator Module with a harness to connect it to the ODB-II connector must be installed.

**Note:** The ODB-II connector and wiring is accessed under the dash.

There are two scenarios:

- I. The J1939 Translator Module is installed as a component with governor kit (no Seat Belt Monitoring System is installed).

Install the J1939 Translator Module and the ODB-II interconnecting harness (provided with the governor kit). A 2-Pin connector is provided for the wires to governor.

- II. The J1939 Translator Module is installed as part of the NFPA1901 compliant Seat Belt Monitoring and VDR System.

The Translator Module/ODB-II/VDR harness is under the driver side dash. A T-cable (provided with the governor kit) needs to be installed at the 4-Pin connector that is between the harness and the VDR.

## Stationary Elevated Idle Control (SEIC) Interface Information

**Note:** Access wires for SEIC are located in cabin, tagged and bundled above the parking brake pedal assembly behind datalink connector.

SEIC is used in two modes: stationary and split shaft. The governor provides a variable RPM control to the Ford Power train Control Module (PCM) when all enabling conditions are met. Refer to Figure 14 Ford PBA PCM Wiring.

**SEIC Enablers:** Parking brake applied; Foot off of service brake; Vehicle in park; Foot off of accelerator pedal; Vehicle speed is 0 mph (stationary); Engine at a stable base idle speed.

**Note:** Do not press the accelerator or service brake pedal when engaging the fire pump, this prevents the switch into SEIC.

## Install the J1939 Translator Module with the ODB-II Interconnecting Harness or Install the T-cable between 4-Pin connectors.

To install the J1939 Translator Module with ODB-II harness, read and follow the installation instructions provided with the Translator Module kit.

**Note:** The TEST pad on the module circuit board has to be held at ground when the harness connector is plugged into the J1 connector.

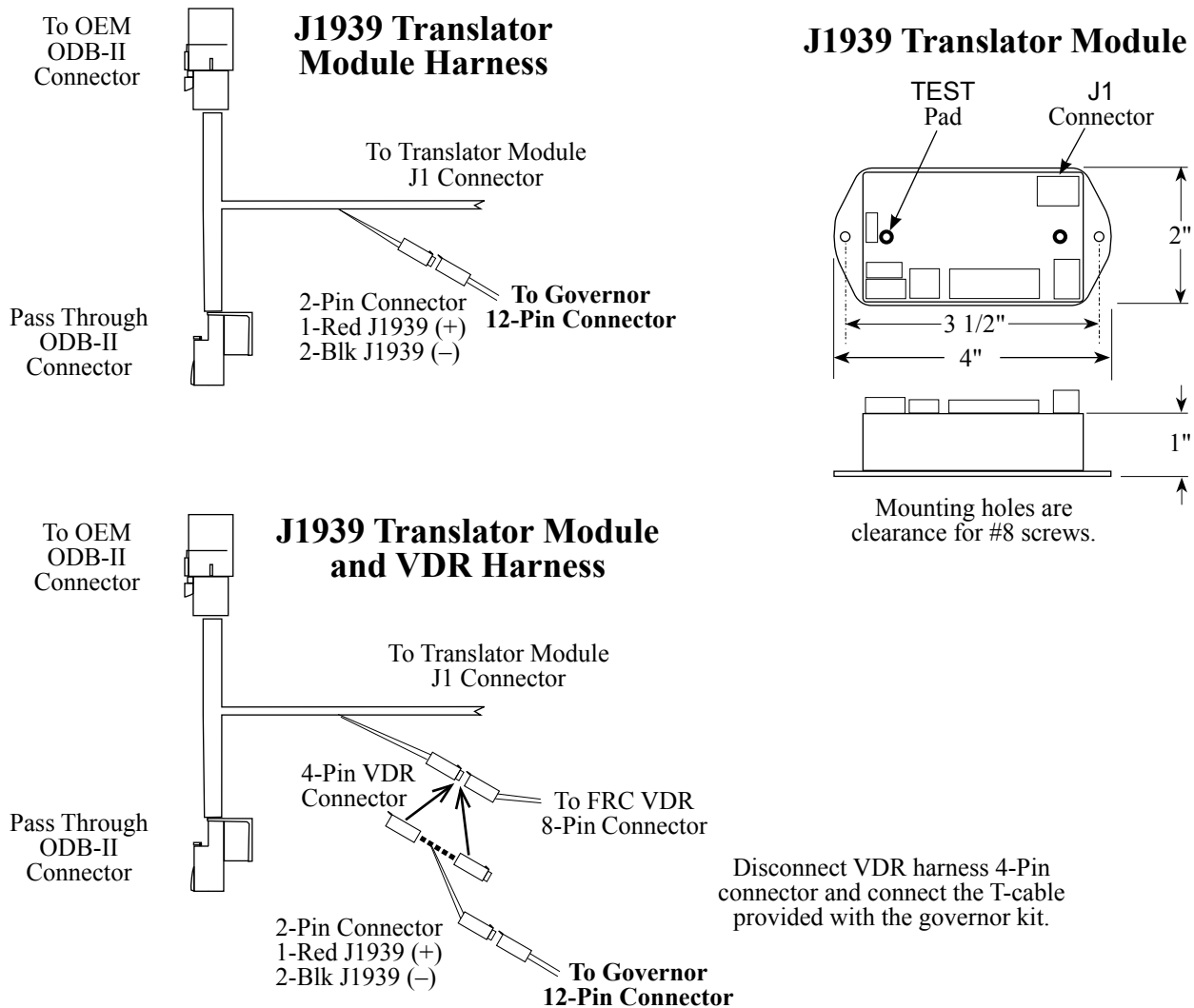

### Translator Module Harness to Governor

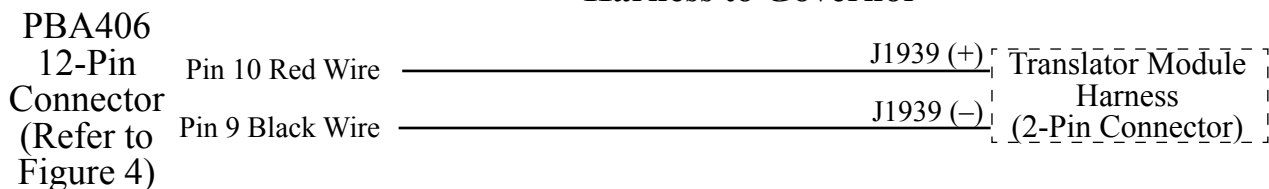

**Note:** Refer to Figure 4. PBA Connector Wiring for governor power and interlock wire connections.

**Figure 13. Ford PBA406 J1939 Translator Module Wiring**

## 2011 Model F-250/350/450/550 - 6.7L Diesel Engine Stationary Elevated Idle Control (SEIC)

**Note:** Do not press the accelerator or service brake pedal when engaging the fire pump, this prevents the switch into SEIC.

**Note:** Refer to Figure 4. PBA Connector Wiring for power and interlock wire connections.

Access wires for SEIC are located in cabin, tagged and bundled above the parking brake pedal assembly behind datalink connector.

### Stationary Mode

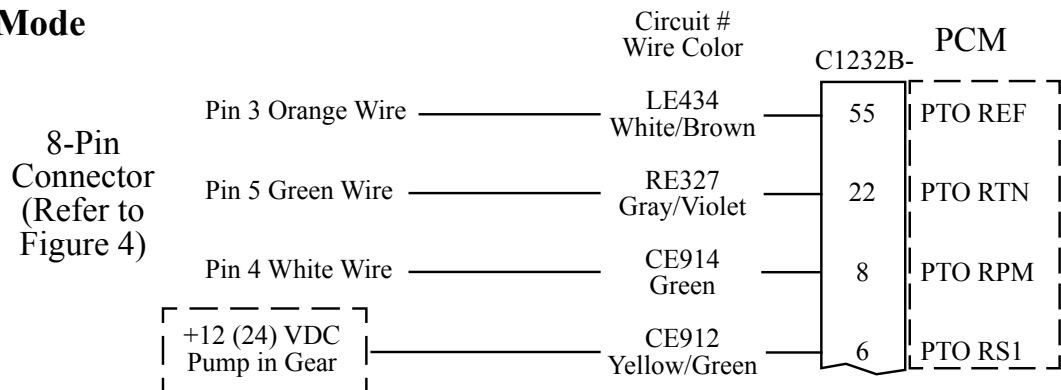

### Split Shaft Mode

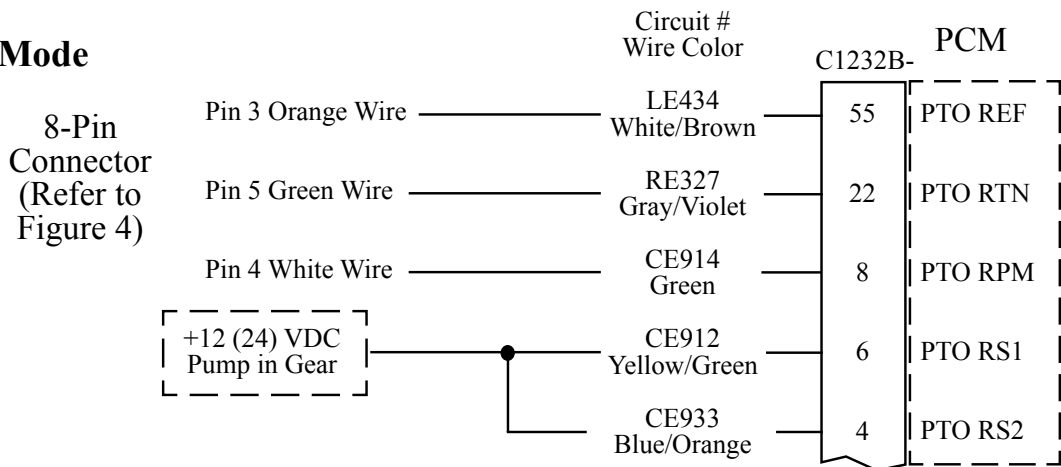

Split Shaft Mode is activated by applying supply voltage to both the PTORS1 and PTORS2 PCM circuits simultaneously.

1. Assure engine is running and fully warmed-up.
2. Apply parking brake.
3. Transmission in neutral to disengage drive wheels.
4. **With foot off brake and accelerator**, switch Split-Shaft PTO on.
5. **While pressing the service brake, shift transmission into drive.**
6. Engage PTO load.

**NOTE:** \*Refer to Ford SVE Bulletin for SEIC details. (For 2017, see Q-256 Ford bulletin.)  
(For 2016 and older, see Q-180R4 Ford SVE Bulletin.)

Once the system enablers are met voltage may be added to the SEIC system for activation. If power is applied prior to the enablers being met, a system error may occur, and the SEIC system will have to be reset.

If an SEIC disabler occurs the engine requires a change-of-state, meaning the operator is required to turn off voltage to the PTO-Request circuit, and back on again to re-invoke SEIC and PTO operation.

**Figure 14. Ford PBA406 PCM Wiring**

# Mack Harness Connections

## Interface Information.

For V-MACK IV 07 and newer, the governor is designed to control engine throttle directly over the SAE J1939 databus.

**Note:** Refer to Figure 4. PBA Connector Wiring for power and interlock wire connections.

### J1939 CAN Bus Control

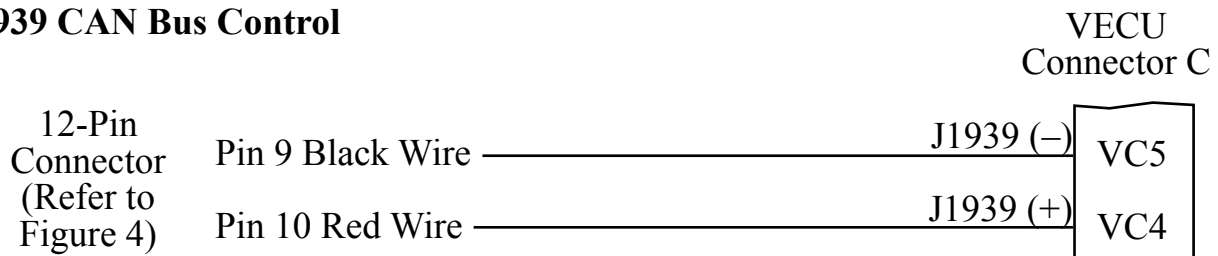

Figure 15. Mack PBA407 Wiring



# Scania Harness Connections—Type A

## Interface Information

For use on P, R, and T-series trucks equipped with a bodywork control unit (BWS). Connector C259 is available on all vehicles ordered with any of the bodywork options. It is located on the plate for the electrical bodywork interface for body builders. Connector C259 is white and has 21 pins. (February 2005 to 2015.)

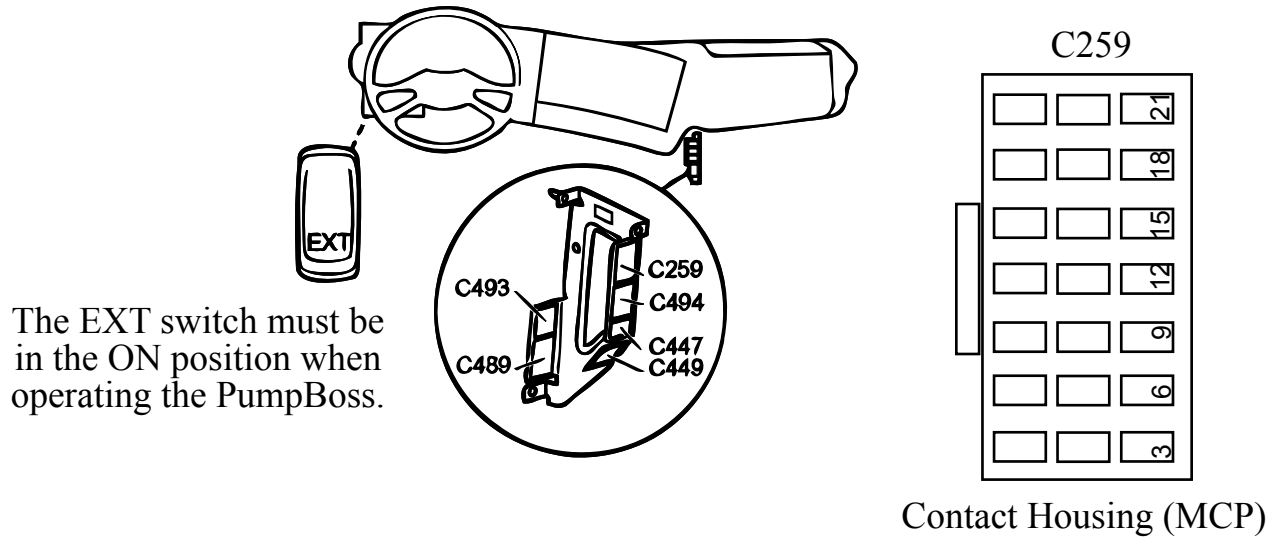

**Note:** Refer to Figure 4. PBA Connector Wiring for power and interlock wire connections.

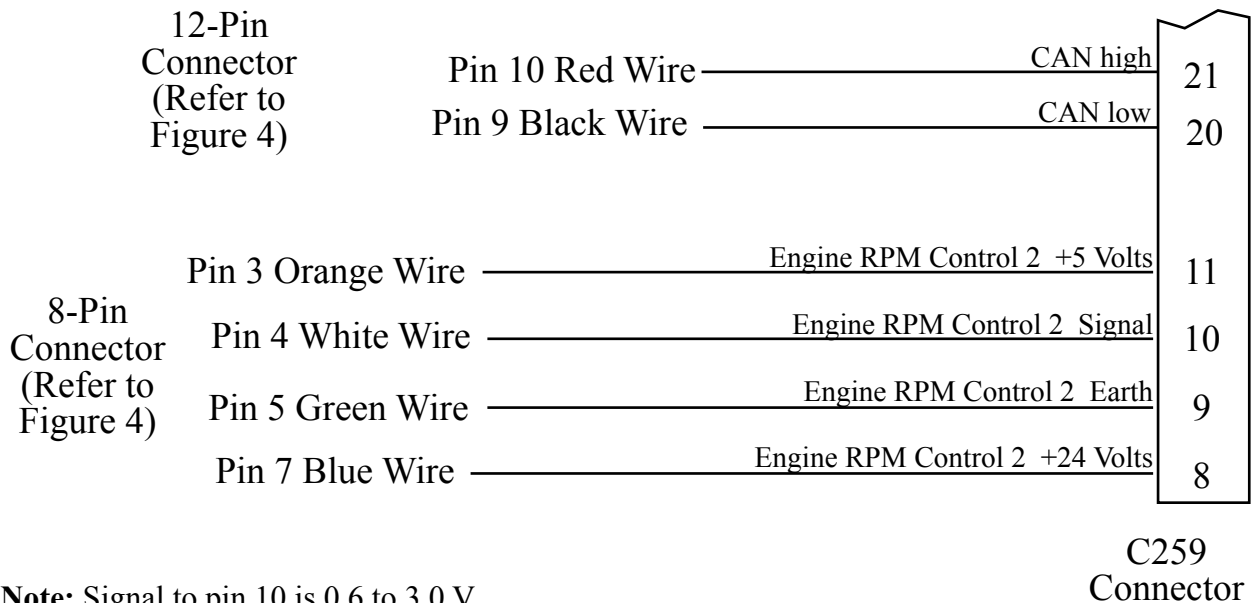

**Note:** Signal to pin 10 is 0.6 to 3.0 V

**Figure 16. Scania PBA408 Wiring—Type A**

# Scania BCI Harness Connections—Type D

## Interface Information

For use with BCI (Bodywork Communication Interface) module.

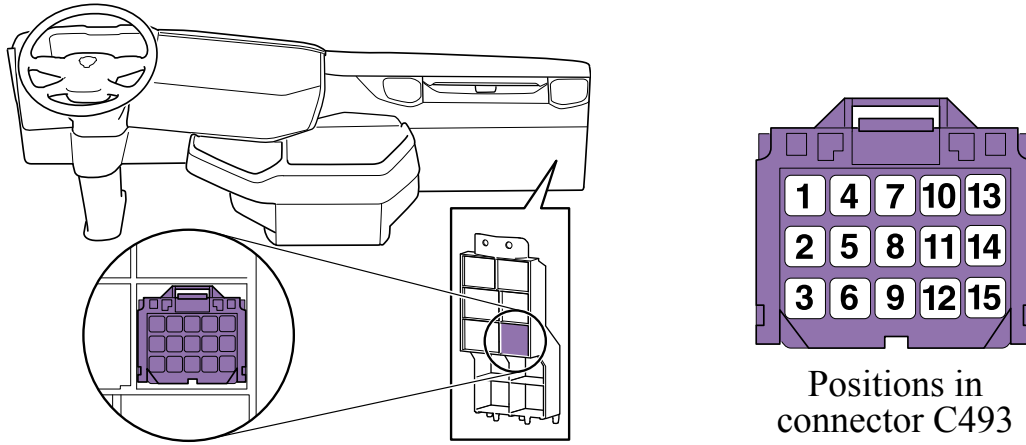

Connector C493 is located in the bodywork console.

**Note:** Refer to Figure 4. PBA Connector Wiring for power and interlock wire connections.

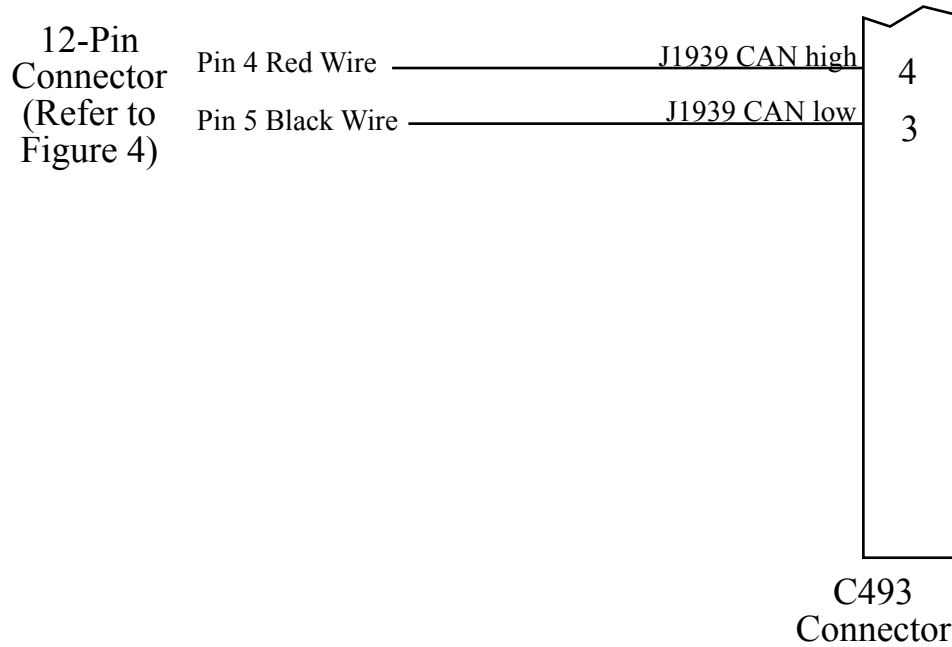

Figure 17. Scania BCI PBA408 Wiring—Type D

# Mercedes Harness Connections

## Interface Information.

For 2007 and newer engines, the governor is designed to control engine throttle directly over the SAE J1939 databus. Remote throttle does not need to be enabled in the ECM.

**Note:** Refer to Figure 4. PBA Connector Wiring for power and interlock wire connections.

### For 2007 and Newer Engines

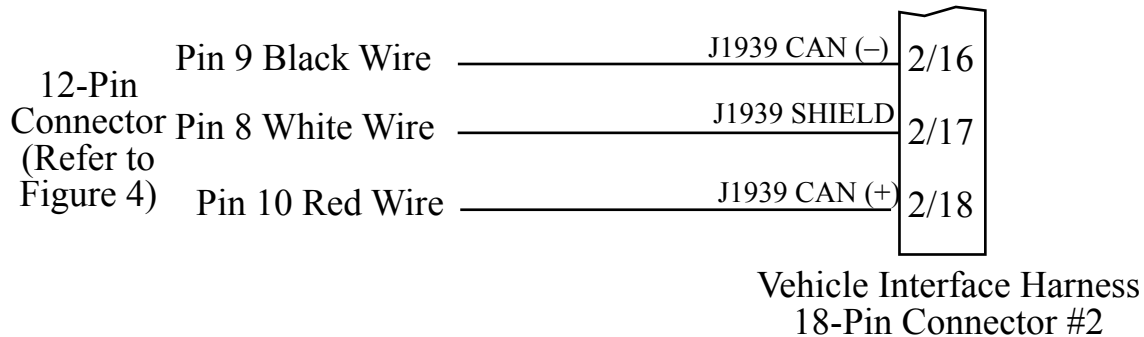

### For 2006 and Older Engines

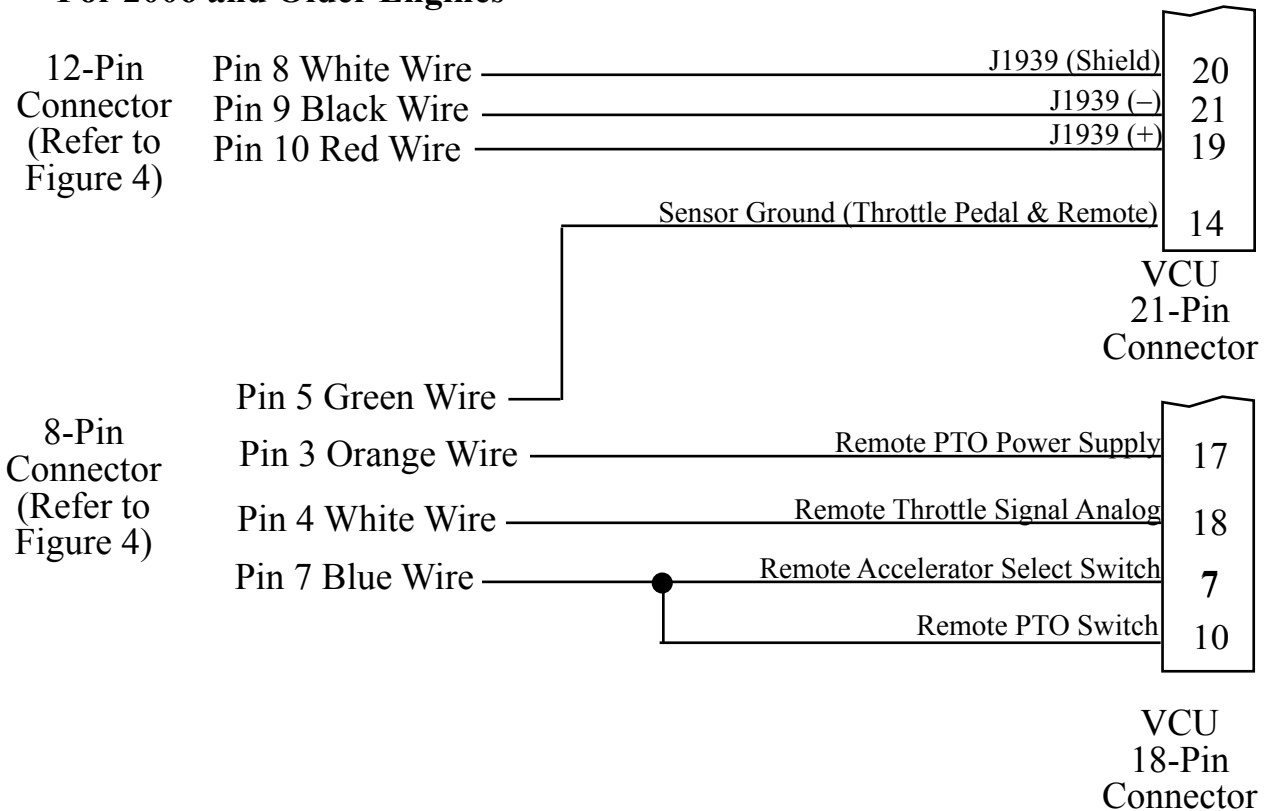

**Figure 18. Mercedes PBA410 Wiring**

# John Deere Harness Connections

## Interface Information

CAN Controller will request a torque by means of TSC1. This option is disabled by default and is selectable in the Trim Options page for this application. Source address 57 should be programmed.

**Note:** Refer to Figure 4 Connector Wiring for Power and Interlock wire connections.

### J1939 CAN Bus Control

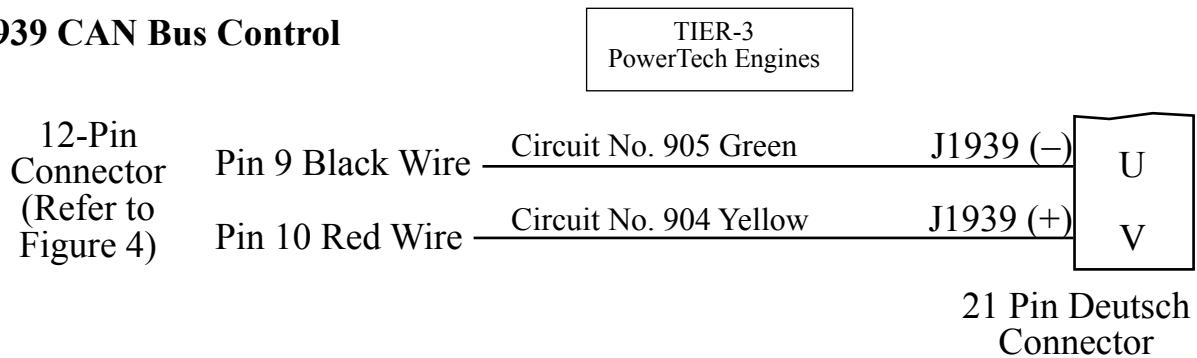

**Figure 19. John Deere PBA416 Wiring**

# MAN Harness Connections

## Interface Information

Parameters for various functions can be set on the KSM using MAN-cats II.

The KSM can accept the Engine speed request from the Governor on the A-CAN.

**Note:** Refer to Figure 4 Connector Wiring for Power and Interlock wire connections.

### J1939 CAN Bus Control

18-Pin Connector  
X1997

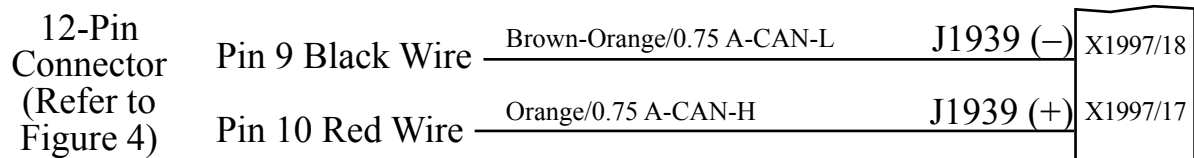

**Figure 20. MAN PBA424 Wiring**

# IVECO Harness Connections

## Interface Information

The vehicles shall be ordered with EM w/ CANopen (OPT0384) and FMS (OPT14569). The CANopen XDC needs to be downloaded. This service is available from the official IVECO TeleService tool-chain worldwide. Also an adapter cable needs to be installed to connect Controller to the CAN Bus. This option is currently available only for EURO CARGO-V.

**Note:** Refer to Figure 4 for the Connector Wiring for Power and Interlock wire connections.

## CAN Bus Control

Vehicle Interface Harness  
9 Pin 72072C Connector

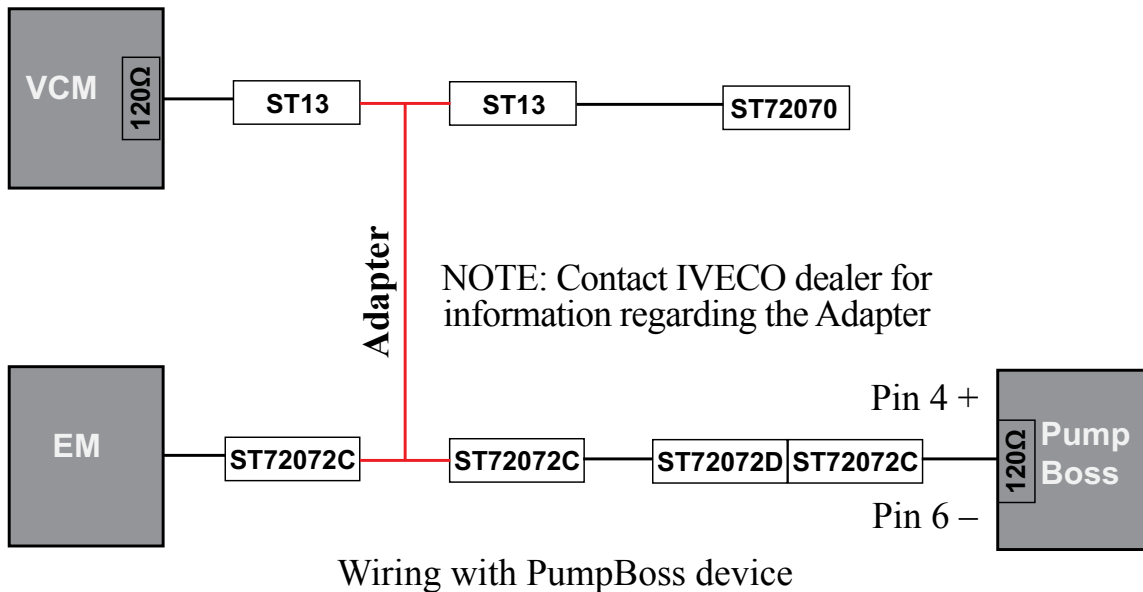
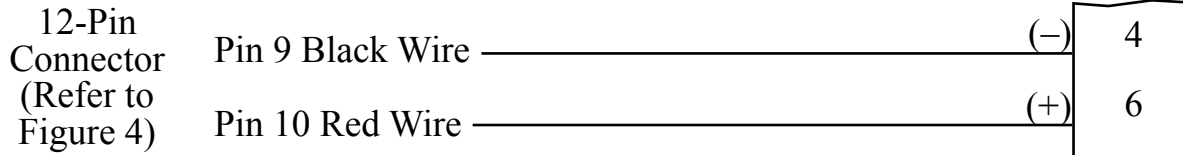

Figure 21. IVECO PBA426 Wiring

## High-Idle Wiring

The governor programming includes a high-idle function. To activate the high-idle provide + VDC to pin 7 (High-Idle Active Input) of the 12-pin connector and pin 6 (Interlock Input) of the 8-pin connector. The high-idle connection to pin 6 must be isolated from the interlock circuit using two diodes (see schematic).

**Note:** It is important that the connection to the Interlock Input from the High-Idle circuit be isolated from the apparatus interlock wiring with the two diodes. Refer to the wiring diagram. **The pump must NOT be engaged when using the high idle function.**

The high-idle is set at about 1000 RPM at the factory. (This value will vary depending on the specific engine.) To adjust this setting refer to High-Idle in the Operation Section.

A High-Idle Kit is available from FRC.

Includes:

**ON/OFF Switch**

**Indicator Light**

**Two Diodes**

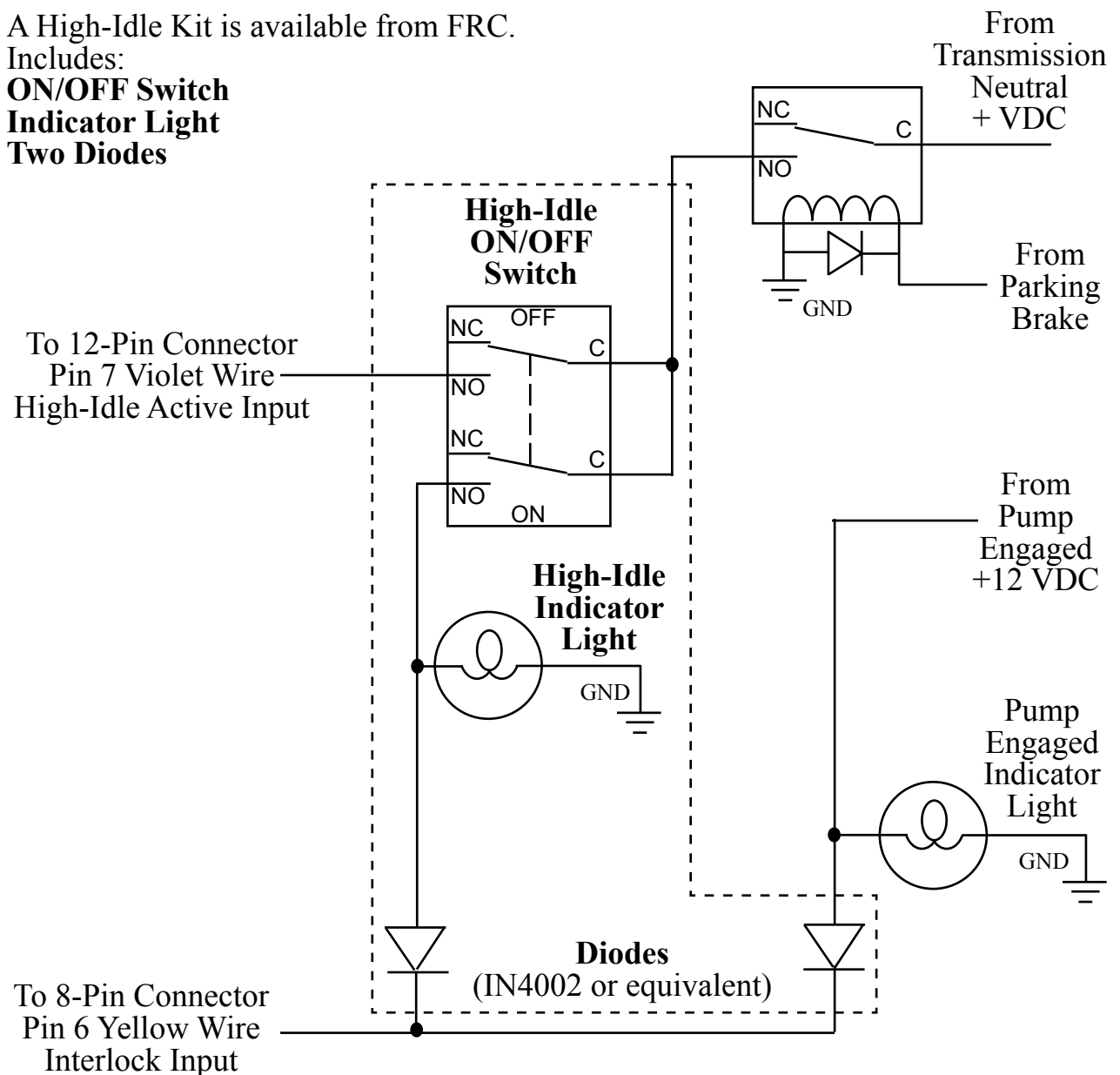

**Figure 22. High-Idle Wiring**

## FLYBACK DIODE INFORMATION

It is good engineering practice to include a flyback diode when switching an inductive load (solenoid coil, relay coil, electric motor winding, etc.). It is recommended that a flyback diode be installed on inductive devices that share a common power source/ground with an FRC governor.

Typical circuit showing a flyback diode installed across an inductive load.

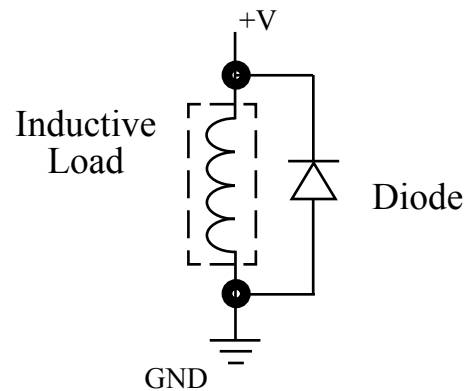
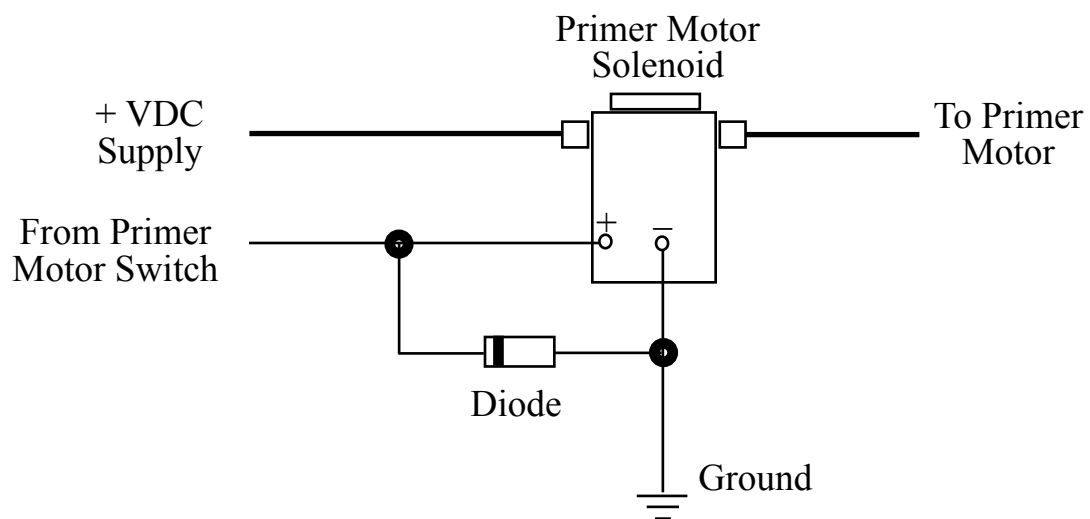

Diagram showing a flyback diode connected on a typical pump primer motor solenoid.



**Figure 23. Flyback Diode**



---

## NOTES

---

**NOTES**

---

**NOTES**



### **PERSONAL RESPONSIBILITY CODE**

The member companies of FEMSA that provide emergency response equipment and services want responders to know and understand the following:

1. Firefighting and Emergency Response are inherently dangerous activities requiring proper training in their hazards and the use of extreme caution at all times.
2. It is your responsibility to read and understand any user's instructions, including purpose and limitations, provided with any piece of equipment you may be called upon to use.
3. It is your responsibility to know that you have been properly trained in Firefighting and/or Emergency Response and in the use, precautions, and care of any equipment you may be called upon to use.
4. It is your responsibility to be in proper physical condition and to maintain the personal skill level required to operate any equipment you may be called upon to use.
5. It is your responsibility to know that your equipment is in operable condition and has been maintained in accordance with the manufacturer's instructions.
6. Failure to follow these guidelines may result in death, burns or other severe injury.



Fire and Emergency Manufacturers and Services Association, Inc.  
P.O. Box 147, Lynnfield, MA 01940 [www.FEMSA.org](http://www.FEMSA.org)

Copyright 2006 FEMSA. All Rights Reserved